



# Deck Design Guide

*May 2015*

The Corporation of the Town of Cobourg

Building and Planning Department

55 King Street West

Cobourg, ON, K9A 2M2

905-372-1005

*This guide is for informational purposes only. It is the responsibility of the Applicant/Designer to review the building code to ensure all information is complete, accurate, and up to date.*

TOWN OF COBOURG

# DECK GUIDE

## DEFINITIONS

A '**Deck**' is a raised uncovered platform that is attached to a dwelling. A deck will generally require a Building Permit and will require protective guards if it has a walking surface greater than 24" above grade.

A '**Porch**' is a covered structure that usually forms part of the entrance of a dwelling. It may be enclosed or unenclosed. Any Porch requires a Building Permit and will require protective guards if it has a walking surface greater than 24" above grade.

A '**Patio**' is an uncovered platform at grade level that is usually constructed of concrete or stone. A Patio generally does not require a Building Permit, unless it interferes with an existing structure.

*NOTE: All Decks, Porches, Patios, and other structures must conform to the Town's Zoning By-Law requirements.*

## IMPORTANT NOTES

**A Deck is a floor system, the same as that within the dwelling unit, and must be designed accordingly.**

The design and construction of the Deck must conform to the requirements of the current amended version of the Ontario Building Code as well as all other applicable by-laws.

Special consideration must be taken if the Deck is to be used to support a hot tub or similar structure due to the increased load.

This guide is for informational purposes only. It is the responsibility of the Applicant/Designer to review the building code to ensure all information is complete, accurate, and up to date.

This Deck Guide should be read in conjunction with "Building Permits – A Homeowners Guide"



# EXAMPLE DRAWING

-THIS EXAMPLE DRAWING CONTAINS THE MINIMUM REQUIRED INFORMATION FOR BUILDING PERMIT SUBMISSION.

-THIS DRAWING IS AN EXAMPLE ONLY AND ALL SUBMISSIONS MUST CONFORM TO THE CURRENT VERSION OF THE ONTARIO BUILDING CODE.

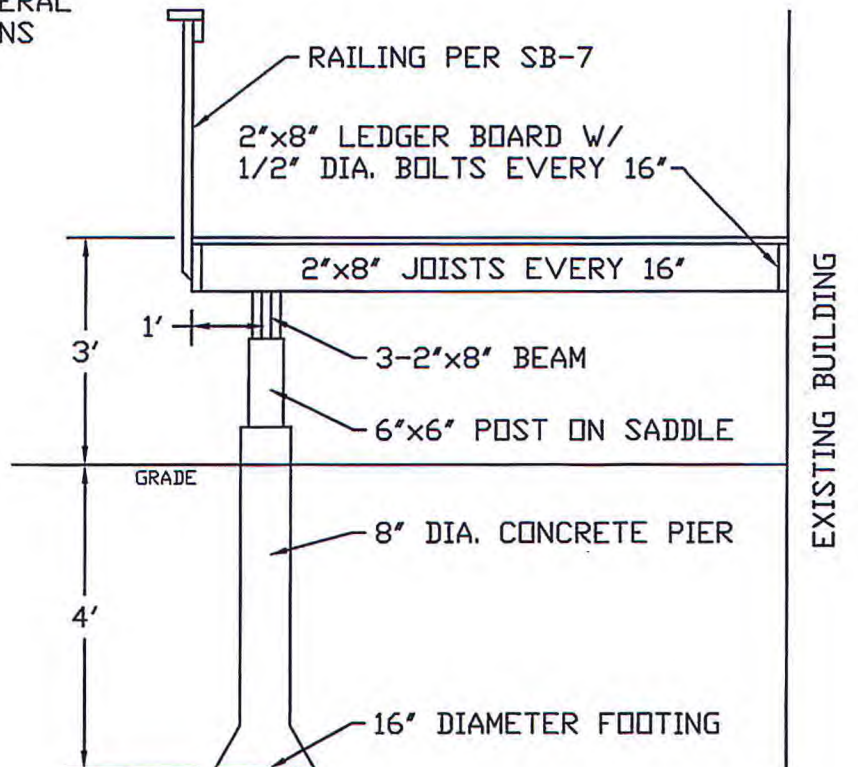
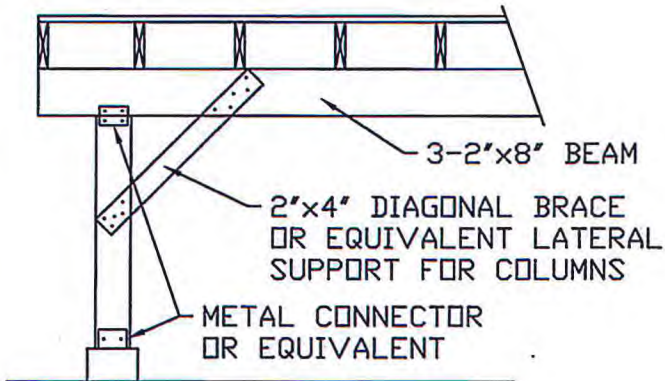
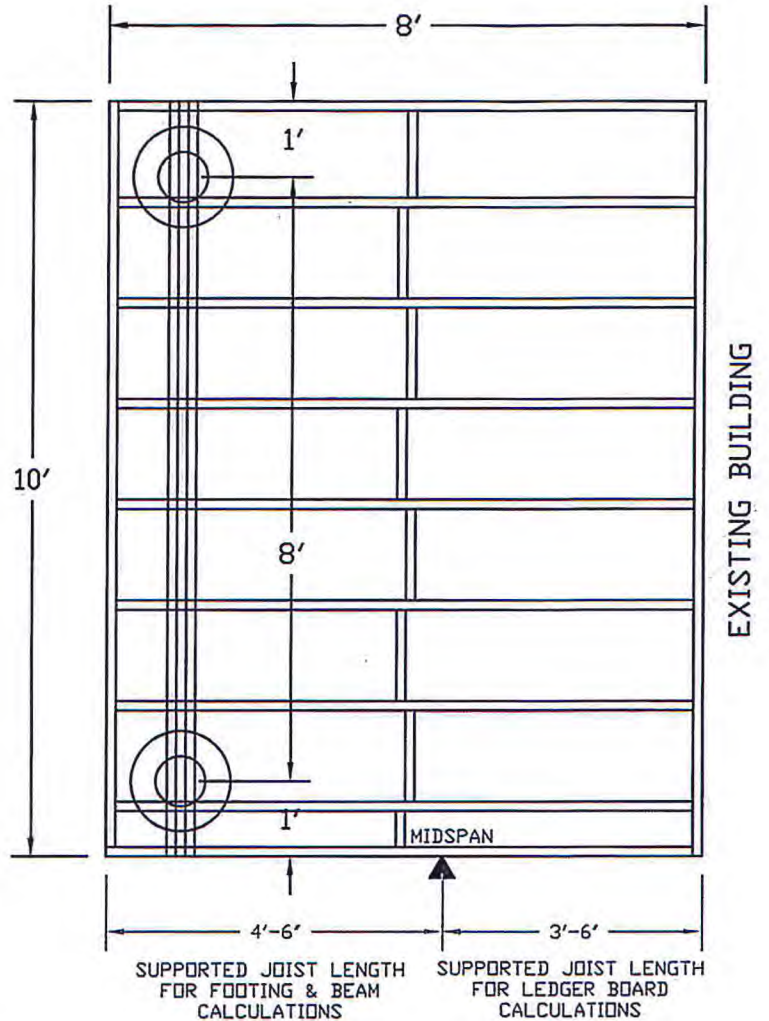

## GENERAL INFORMATION

### PIERS

General:

-Piers used shall be not less than 8" in diameter.

*NOTE: Under most circumstances it may be preferable to expand the lower portion of a smaller pier to achieve the required bearing area rather than use a large pier size.*

Size: Table 9.15.3.4.

Minimum Footing Size = 0.40 (4.3 ft<sup>2</sup>) where; the supported joist length is 4.90 (16'), the pier spacing is 3.00 (10'), and the soil bearing capacity is 75 kPa (10.9 psi). Minimum size specified may be adjusted based on the specific supported joist length, pier spacing, and soil bearing capacity. *NOTE: The minimum required bearing area must be doubled where the soil bearing capacity is affected by a high water table.*

<b>MINIMUM REQUIRED BEARING AREA [ft<sup>2</sup>] (Typical Bearing Dimensions)</b>							
<b>75kPa Soil Bearing Capacity</b>		<b>Beam Length / Pier Spacing (ft)</b>					
		<b>4'</b>	<b>6'</b>	<b>8'</b>	<b>10'</b>	<b>12'</b>	<b>14'</b>
<b>Supported Joist Length (ft) (Refer to Illustration)</b>	<b>4'</b>	0.43 ft <sup>2</sup> (10" Ø or 8"x8")	0.65 ft <sup>2</sup> (12" Ø or 10"x10")	0.86 ft <sup>2</sup> (14" Ø or 12"x12")	1.08 ft <sup>2</sup> (14" Ø or 13"x13")	1.29 ft <sup>2</sup> (16" Ø or 14"x14")	1.51 ft <sup>2</sup> (18" Ø or 15"x15")
	<b>6'</b>	0.65 ft <sup>2</sup> (12" Ø or 10"x10")	0.97 ft <sup>2</sup> (14" Ø or 12"x12")	1.29 ft <sup>2</sup> (16" Ø or 14"x14")	1.61 ft <sup>2</sup> (18" Ø or 16"x16")	1.94 ft <sup>2</sup> (20" Ø or 17"x17")	2.26 ft <sup>2</sup> (22" Ø or 19"x19")
	<b>8'</b>	0.86 ft <sup>2</sup> (14" Ø or 8"x8")	1.29 ft <sup>2</sup> (16" Ø or 14"x14")	1.72 ft <sup>2</sup> (18" Ø or 16"x16")	2.15 ft <sup>2</sup> (20" Ø or 18"x18")	2.58 ft <sup>2</sup> (22" Ø or 20"x20")	3.01 ft <sup>2</sup> (24" Ø or 21"x21")
	<b>10'</b>	1.08 ft <sup>2</sup> (14" Ø or 13"x13")	1.61 ft <sup>2</sup> (18" Ø or 16"x16")	2.15 ft <sup>2</sup> (20" Ø or 18"x18")	2.69 ft <sup>2</sup> (24" Ø or 20"x20")	3.23 ft <sup>2</sup> (N/A Ø or 22"x22")	3.76 ft <sup>2</sup> (N/A Ø or 24"x24")
	<b>12'</b>	1.29 ft <sup>2</sup> (16" Ø or 14"x14")	1.94 ft <sup>2</sup> (20" Ø or 17"x17")	2.58 ft <sup>2</sup> (22" Ø or 20"x20")	2.82 ft <sup>2</sup> (24" Ø or 21"x21")	3.87 ft <sup>2</sup> (N/A Ø or 24"x24")	4.52 ft <sup>2</sup> (N/A Ø or 26"x26")
	<b>14'</b>	1.51 ft <sup>2</sup> (18" Ø or 15"x15")	2.26 ft <sup>2</sup> (22" Ø or 18"x18")	3.01 ft <sup>2</sup> (24" Ø or 21"x21")	3.76 ft <sup>2</sup> (N/A Ø or 24"x24")	4.52 ft <sup>2</sup> (N/A Ø or 26"x26")	5.27 ft <sup>2</sup> (N/A Ø or 28"x28")
	<b>16'</b>	1.72 ft <sup>2</sup> (18" Ø or 16"x16")	2.58 ft <sup>2</sup> (22" Ø or 20"x20")	3.44 ft <sup>2</sup> (N/A Ø or 23"x23")	<b>4.30 ft<sup>2</sup></b> (N/A Ø or 25"x25")	5.16 ft <sup>2</sup> (N/A Ø or 28"x28")	6.02 ft <sup>2</sup> (N/A Ø or 30"x30")

Piers: 9.3.1.6.(1)

-Piers shall consist of poured concrete with a minimum compressive strength of 15 MPa (2200 psi after 28 days)

Depth: 9.12.2.2.

-Where a deck is attached to a dwelling unit or requires a guard the piers must extend a minimum of 1.2m (3'-11") below grade.

Height: 9.15.2.3.(3)

-Piers shall not extend more than 3 times their width above grade.

## **COLUMNS**

Size: 9.17.4.1.(2)

-Wood columns shall be not less than 184 (7-1/4") for round columns and 140 x 140 (5-1/2"x5-1/2") for rectangular columns.

Anchorage: 9.23.6.2.

-Columns shall be directly fastened to their supporting and supported members to resist uplift.

## **LEDGER BOARD**

Size and Attachment: 9.20.17.5

-A Ledger Board shall have the same dimensions as the floor joists it supports.

-Anchor Bolts shall be embedded at least 100mm (4") into solid concrete, concrete filled masonry, or suitable structural lumber. *NOTE: The anchor bolts shall not be attached to hollow masonry or brick veneer.*

Supported Length, m (ft)	Maximum Anchor Bolt Spacing, mm (in)	
	Staggered 12.7mm (1/2") Ø Anchor Bolts	Staggered 16mm (5/8") Ø Anchor Bolts
1.22 (4'-0")	450 (17-3/4")	500 (20")
1.50 (4'-9")	400 (16")	450 (17-3/4")
2.00 (6'-6")	300 (12")	400 (16")
2.50 (8'-2")	275 (11")	325 (12-3/4")

## **BEAMS**

9.23.4.2.(3) Table A-8

Supported Length (m) <sup>(1)</sup>	Maximum Span (m)		
	3-38x184 (3-2"x8")	3-38x235 (3-2"x10")	3-38x286 (3-2"x12")
2.40 (7.87')	3.07 (10'-0")	3.92 (12'-10")	4.57 (14'-11")
3.00 (9.84')	2.85 (9'-4")	3.52 (11'-6")	4.09 (13'-5")
3.60 (11.8')	2.63 (8'-7")	3.22 (10'-6")	3.73 (12'-2")
4.20 (13.7')	2.44 (8'-0")	2.98 (9'-9")	3.46 (11'-4")
4.80 (15.7')	2.28 (7'-5")	2.79 (9'-1")	3.23 (10'-7")
5.40 (17.7')	2.15 (7'-0")	2.63 (8'-7")	3.05 (10'-0")
6.00 (19.6')	2.04 (6'-8")	2.49 (8'-2")	2.89 (9'-5")

<sup>(1)</sup> Supported length means half the sum of the joists spans on both sides of the beam.

\*Spruce-Pine-Fir No.1 or No.2 Grade

Bearing: 9.17.4.1. & 9.23.8.1.

-Beams shall a bearing surface on each of their supporting member of not less than their width and not less than 89 (3.5") in length.

Built-up wood: 9.23.8.3.

-Where individual members are butted together to form a joint, the joint shall occur over a support.

-Built up beams shall be nailed together with a double row of nails not less than 89 (3.5") in length, not more than 450 (18") apart, and not more than 100 (4") from the end.

## **JOISTS**

Size & Spacing: 9.23.4.2.(1) & Table A-1

Joist Size	Maximum Span (m)		
	300 (12") o.c.	400 (16") o.c.	600 (24") o.c.
38x140 (2"x6")	3.14 (10'-3")	2.85 (9'-4")	2.49 (8'-2")
38x184 (2"x8")	3.81 (12'-6")	3.58 (11'-9")	3.27 (10'-8")
38x235 (2"x10")	4.44 (14'-6")	4.17 (13'-8")	3.92 (12'-10")
38x286 (2"x12")	5.01 (16'-5")	4.71 (15'-5")	4.42 (14'-6")

*\*Spruce-Pine-Fir No.1 or No.2 Grade with Bridging*

*\*The use of floor joists less than 38x184 (2"x8") is not recommended as it does not allow for the proper attachment of railings.*

Cantilever: 9.23.9.9.

-38x184 (2"x8") may not be cantilevered more than 400 (16")

-38x235 (2"x10") or larger may not be cantilevered more than 600 (24")

Bearing: 9.23.9.1. – 9.23.9.3., 9.23.3.4.(1)

-Floor joists may be supported on the tops of beams or may be supported with proper metal joist hangers.

-The floor joists must be mechanically fastened to the supporting member with two 82 (3-1/4") nails.

Bridging: 9.23.9.4.(2), 9.23.3.4.(1)

-Bridging shall consist of 19 x 64 (1"x3") cross bridging, 38 x 38 (2"x2") cross bridging or solid blocking the same dimension as the supported floor joists.

-Bridging shall be located not more than 2100 (6'-11") from each support or other rows of bridging.

-Bridging shall be fastened with two 57 (2-1/4") nails at each end.

## **DECKING**

Requirements: Table 9.23.14.5.A., 9.23.3.5.(1)

-Decking less than or equal to 184mm (7-1/4") wide shall be fastened with two 51mm (2") common/spiral nails or two 45mm (1-3/4") Screws at each support.

-Decking shall consist of solid lumber at least 17.0mm (11/16") thick when joists are spaced 400mm (16") or less and at least 19.0mm (3/4") when joists are spaced more than 400mm (16").

## **FASTENERS**

-All fasteners used must be properly treated/coated to prevent corrosion.

-Equivalent screws may be used in lieu of nails

## **STAIRS**

Stairs shall conform to section 9.8 of the Ontario Building Code

## **RAILING**

Railings shall conform to Supplementary Standard SB-7 of the Ontario Building Code (see attached)

## GUARDS

### 9.8.8.3. Height of Guards

-Exterior guards serving not more than one dwelling unit shall be not less than 900 mm (36") high where the walking surface served by the guard is not more than 1 800 (5'-11") mm above the finished ground level, otherwise the guards shall be not less than 1 070 mm (42") high. If a bench is incorporated into a guard the required height is measured above the bench surface.

### 9.8.8.5. Openings in Guards

-Openings through a guard shall be of a size that will prevent the passage of a spherical object having a diameter of 100 mm (4").

### 9.8.8.6. Design to Prevent Climbing

-Guards shall be designed so that no member, attachment, or opening will facilitate climbing.

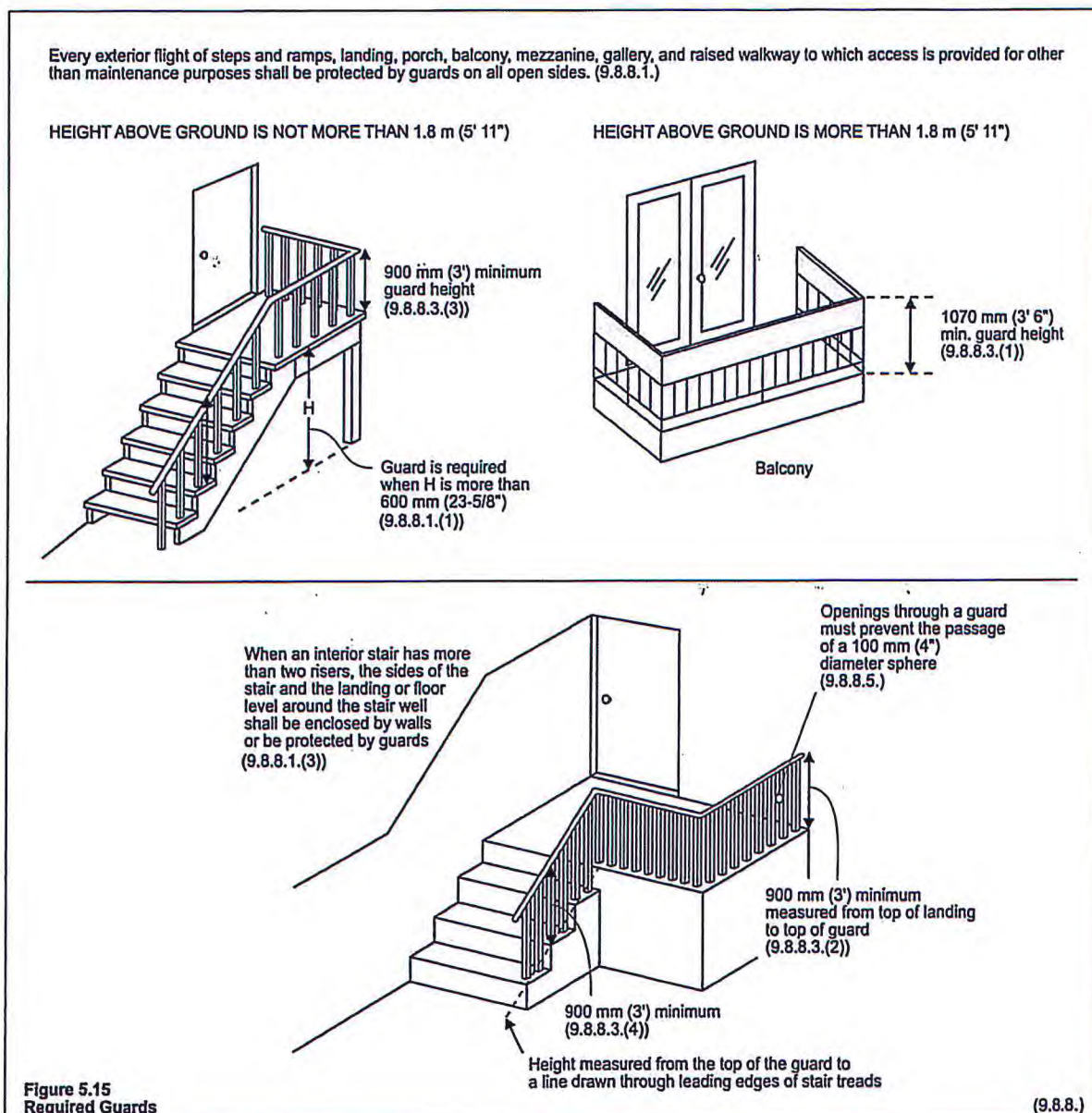
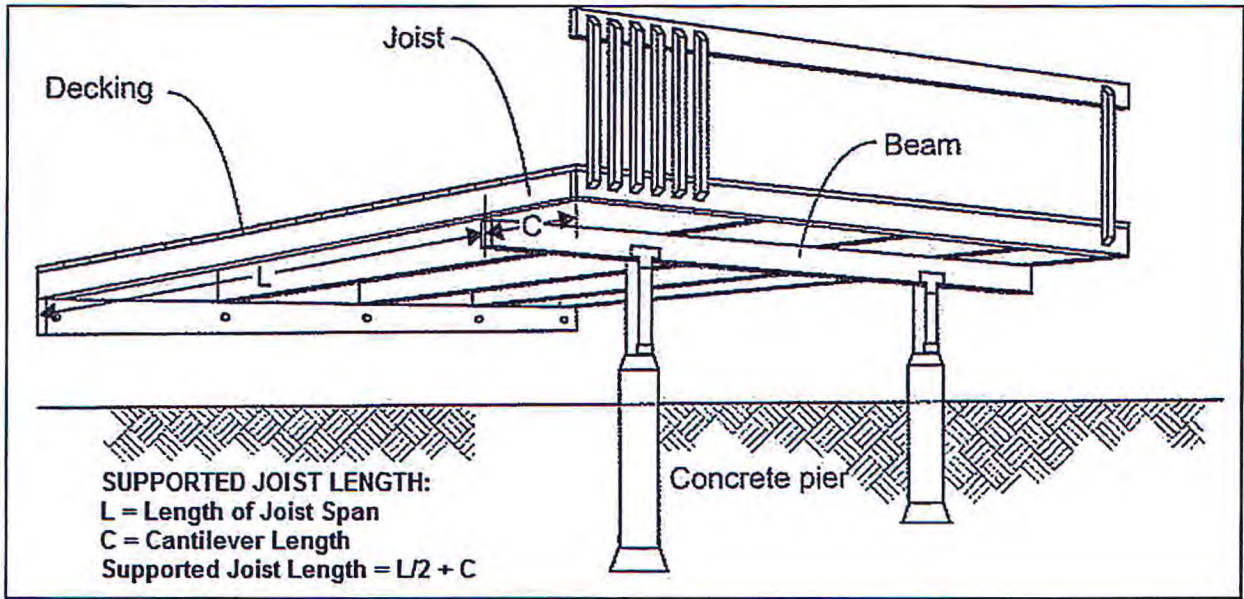

Figure 5.15  
Required Guards



## ILLUSTRATIONS

FROM THE "CODE AND CONSTRUCTION - GUIDE FOR HOUSING"



## PIERS

EXAMPLE: Where Require Bearing Area = 1.29 Sq. Ft.

NOTE: REFER TO PIER TABLE FOR REQUIRED SIZES



16" Dia. Concrete Pier  
Without Footing



8" Dia. Concrete Pier  
With Base Expanded  
To 16" Dia.

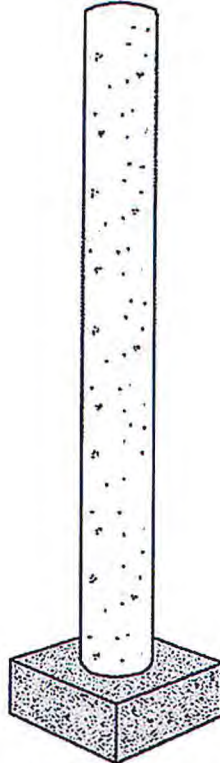

8" Dia. Concrete Pier  
On 14" x 14"  
Concrete Footing

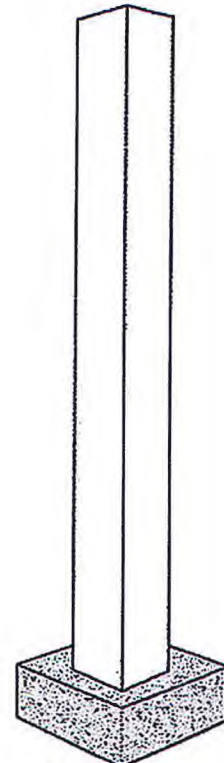

6" x 6" PT Wood Post  
On 14" x 14"  
Concrete Footing

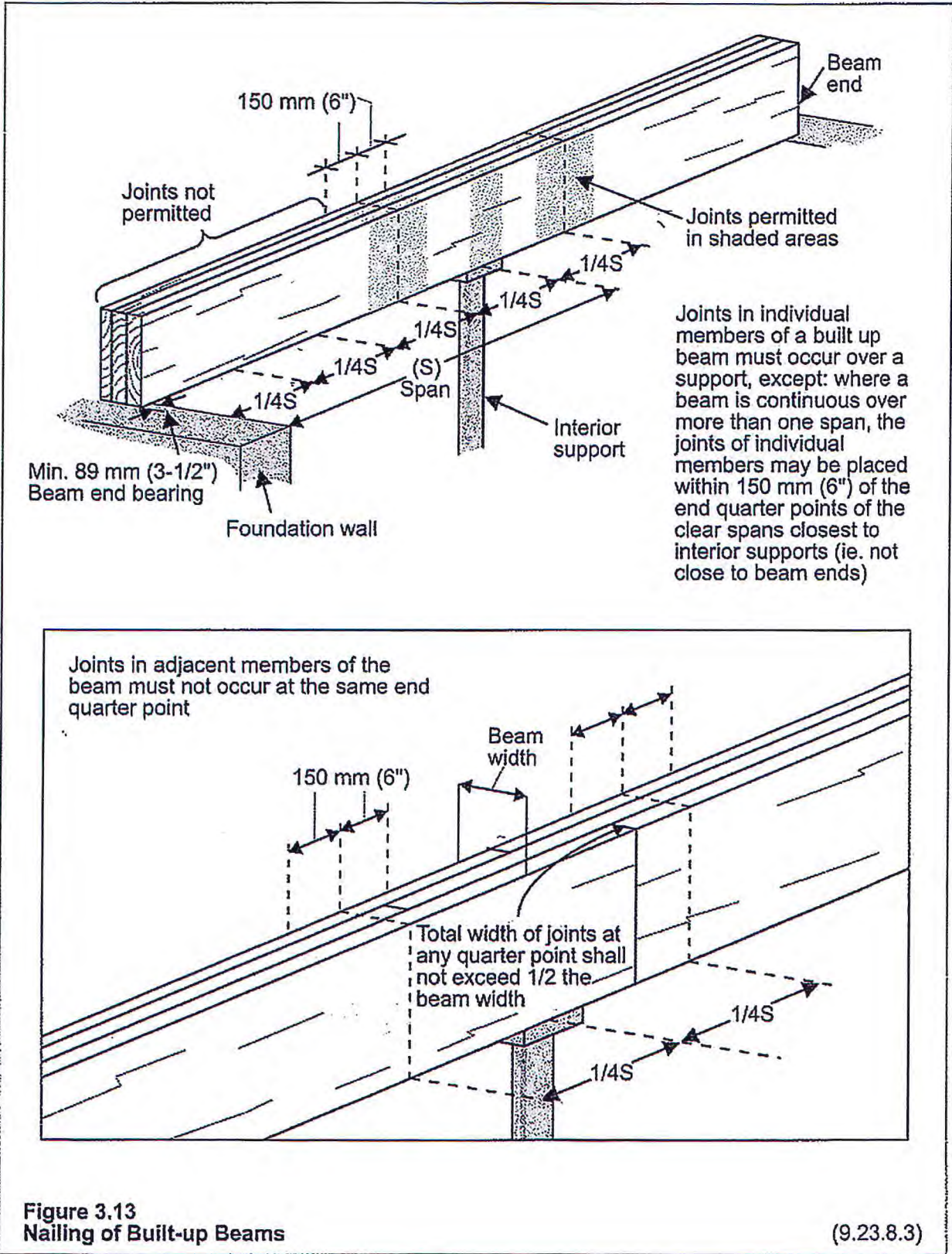

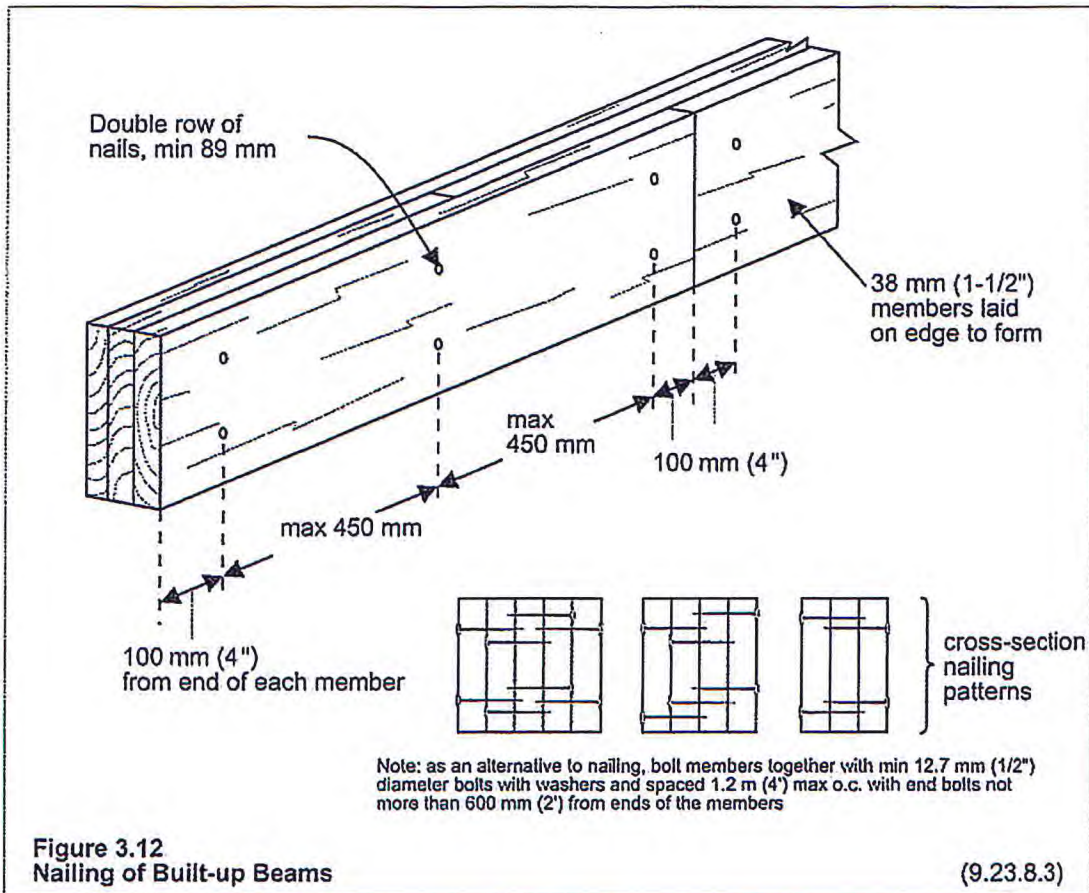

**WOOD STAIRS**

- W = max 900 mm (35") in dwelling units
- W = max 1200 mm (47") in dwelling units when risers support the front of the treads unless stringers and treads designed for wider spacing
- W = max 600 mm (23-1/2") in other than dwelling units

**Tread thickness:**

- A = min 25 mm (1") when risers support front of tread
- B = min 38 mm (1-1/2") when tread unsupported at front and distance between stringers is no greater than 750 mm (30")

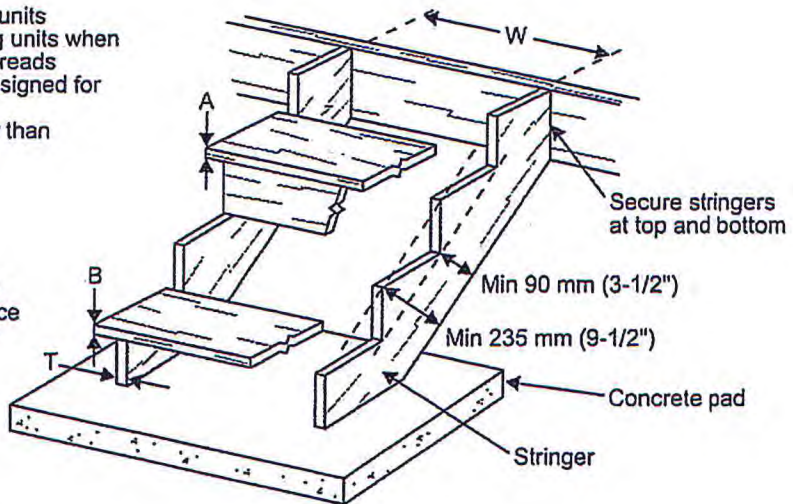

**SINGLE DWELLING UNIT  
INTERIOR AND EXTERIOR STAIRS**

Stair dimensions as shown:  
(9.8.3.1)

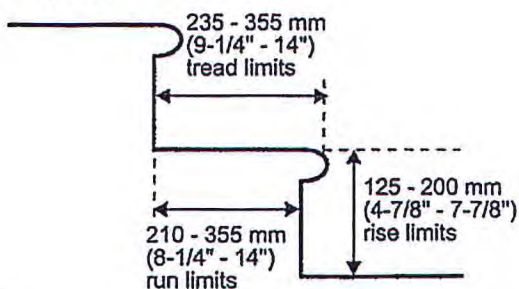

# UNACCEPTABLE INSTALLATION

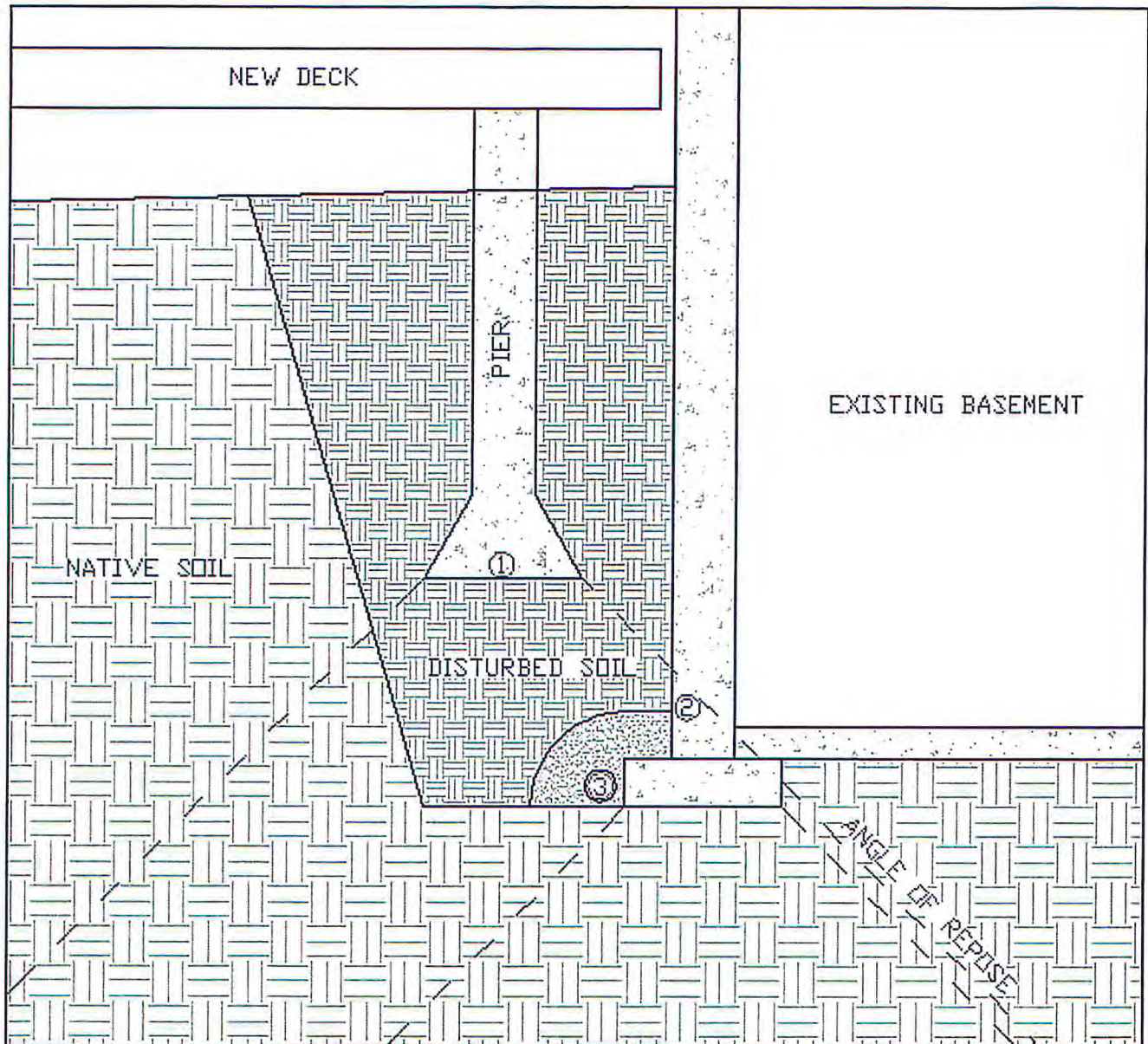

- 1) FOUNDATIONS MUST REST ON UNDISTURBED NATIVE SOIL.
- 2) FOUNDATIONS WITHIN THE ANGLE OF REPOSE REQUIRE THE SERVICES OF A PROFESSIONAL ENGINEER.
- 3) NEW FOUNDATIONS MUST NOT INTERFERE WITH EXISTING FOUNDATION DRAINAGE SYSTEMS.

Table 2.2.1.  
Exterior Post and Rail System Connection Details

Connection Detail	Detail Number	Description
Top Rail to Post and / or Bottom Rail to Post	EA-1	Top rail nailed to post
	EA-2	Top/bottom rail skew nailed to post with 76 mm (3") nails
	EA-3	Top/bottom rail skew nailed to post with 63 mm (2½") nails
	EA-4	Top/bottom rail face nailed or screwed to post
	EA-5	Top/bottom rail fastened to post with framing anchors
Post to Floor	EB-1	Post nailed to rim joist
	EB-2	Post screwed to rim joist
	EB-3	Post bolted to floor joist with 8 mm (5/16") machine bolts
	EB-4	Post bolted to floor joist with 9.5 mm (3/8") machine bolts
	EB-5	Post bolted to 2 floor joists
	EB-6	Post fastened to floor, where guard is parallel to floor joists
Infill Picket	EC-1	Picket nailed to endcap; endcap screwed to rail
	EC-2	Picket nailed to rail
	EC-3	Picket screwed to rail
	EC-4	Picket screwed to top rail and rim joist
Column 1	2	3

Table 2.2.2.  
Exterior Cantilevered Picket System Connection Details

Connection Detail	Detail Number	Description
Cantilevered Picket (Douglas Fir-Larch, Spruce-Pine-Fir, Hem-Fir Species)	ED-1	Picket screwed to rim joist
	ED-2	Picket screwed to rim joist, where guard is parallel to floor joists
Cantilevered Picket (Northern Species)	ED-3	Picket screwed to rim joist and deck
	ED-4	Picket screwed to rim joist and deck, where guard is parallel to floor joists
Cantilevered Picket (Douglas Fir-Larch, Spruce-Pine-Fir, Hem-Fir Species, Northern Species)	ED-5	Corner
Column 1	2	3

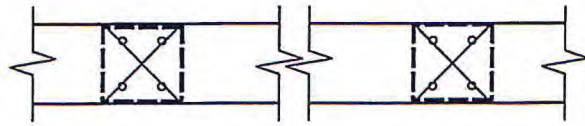

PLAN

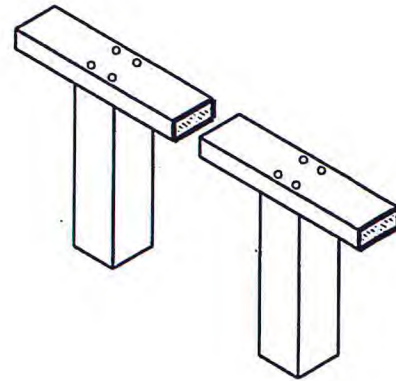

AXONOMETRIC

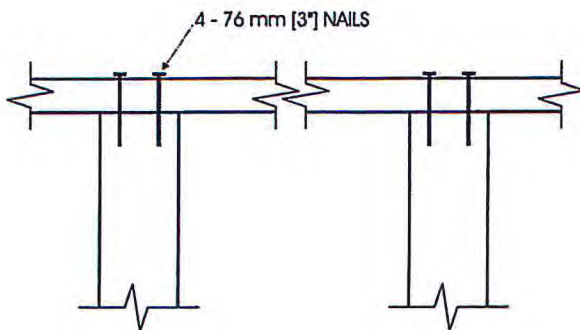

FRONT ELEVATION

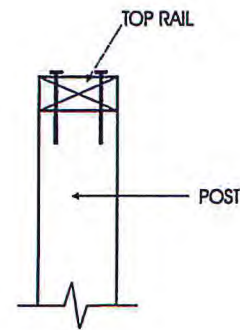

SIDE ELEVATION

**Detail EA-1**

**Exterior Connection: Top Rail Nailed to Post**

**Notes:**

1. The top rail must be continuous. Use Detail EA-5 at the end spans, where continuity ends.

MAXIMUM SPAN OF RAIL BETWEEN POSTS	
Species	Maximum Span, m (ft-in)
Douglas Fir-Larch, Hem-Fir, Spruce-Pine-Fir	1.52 (5'-0")
Northern Species	1.52 (5'-0")
Column 1	2

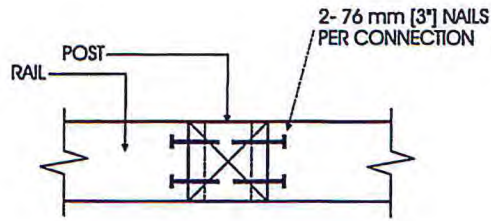

PLAN

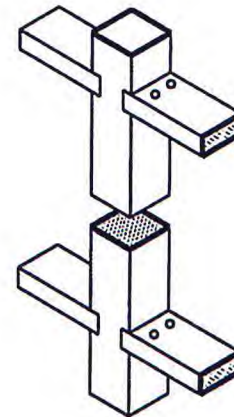

AXONOMETRIC

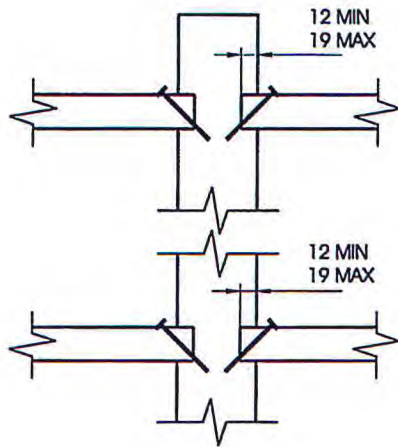

FRONT ELEVATION

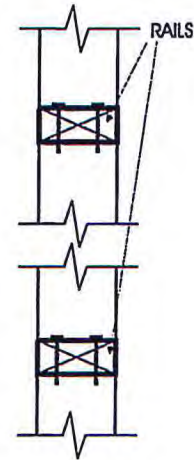

SIDE ELEVATION

**Detail EA-2**

**Exterior Connection: Top/Bottom Rail Skew Nailed to Post - 76 mm (3") Nails**

**Notes:**

1. The maximum span is more often governed by post spacing.
2. Provide support to bottom rail at intervals not more than 2.0 m (6'-7").
3. The bottom rail may be bevelled as detailed in Figure 2.1.2.
4. Dimensions shown are in mm unless otherwise specified.

MAXIMUM SPAN OF RAIL BETWEEN POSTS	
Species	Maximum Span, m (ft-in)
Douglas Fir-Larch, Hem-Fir, Spruce-Pine-Fir	2.72 (8'-11")
Northern Species	2.18 (7'-2")
Column 1	2

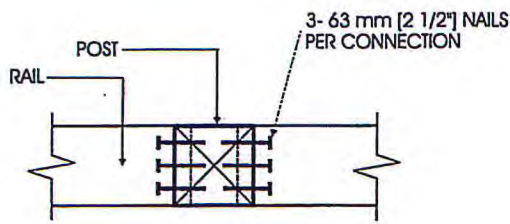

PLAN

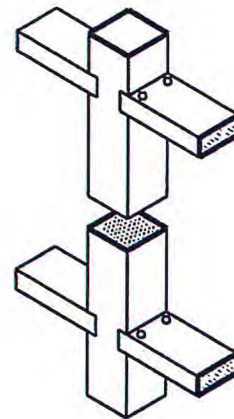

AXONOMETRIC

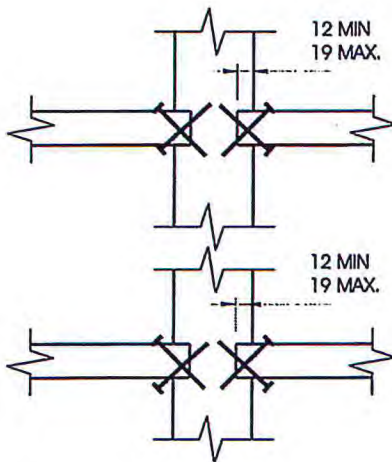

FRONT ELEVATION

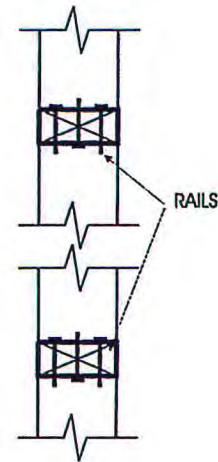

SIDE ELEVATION

**Detail EA-3**

**Exterior Connection: Top/Bottom Rail Skew Nailed to Post - 63 mm (2½") Nails**

**Notes:**

1. Provide support to bottom rail at intervals not more than 2.0 m (6'-7").
2. The bottom rail may be bevelled as detailed in Figure 2.1.2.
3. Dimensions shown are in mm unless otherwise specified.

MAXIMUM SPAN OF RAIL BETWEEN POSTS	
Species	Maximum Span, m (ft-in)
Douglas Fir-Larch, Hem-Fir, Spruce-Pine-Fir	2.72 (8'-11")
Northern Species	2.18 (7'-2")
Column 1	2



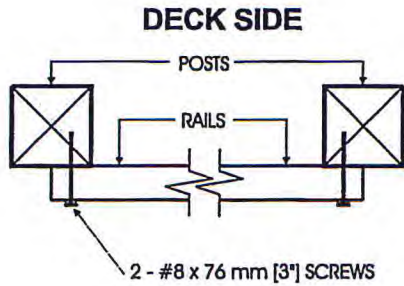

PLAN

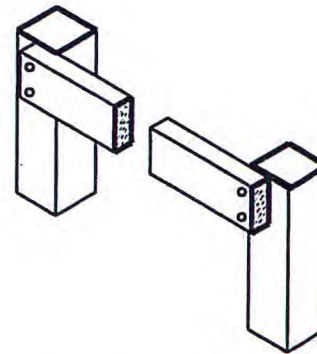

AXONOMETRIC

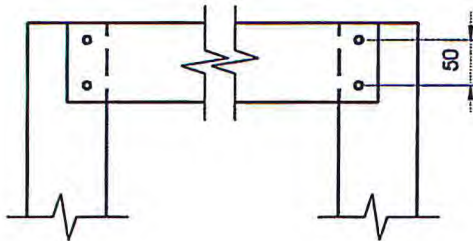

FRONT ELEVATION

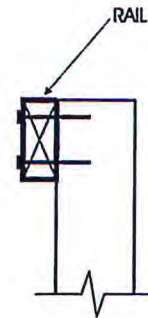

SIDE ELEVATION

**Detail EA-4**

**Exterior Connection: Top/Bottom Rail Face Nailed or Screwed to Post**

**Notes:**

1. If the rails are located on the deck side of the posts, 76 mm (3") nails may be used in place of the screws.
2. Where the top rail is continuous, the top rail may be fastened to each post with 3 - #8 x 76 mm (3") screws.
3. Dimensions shown are in mm unless otherwise specified.

MAXIMUM SPAN OF RAIL BETWEEN POSTS	
Species	Maximum Span, m (ft-in)
Douglas Fir-Larch, Hem-Fir, Spruce-Pine-Fir	1.77 (5'-10")
Northern Species	1.41 (4'-8")
Column 1	2

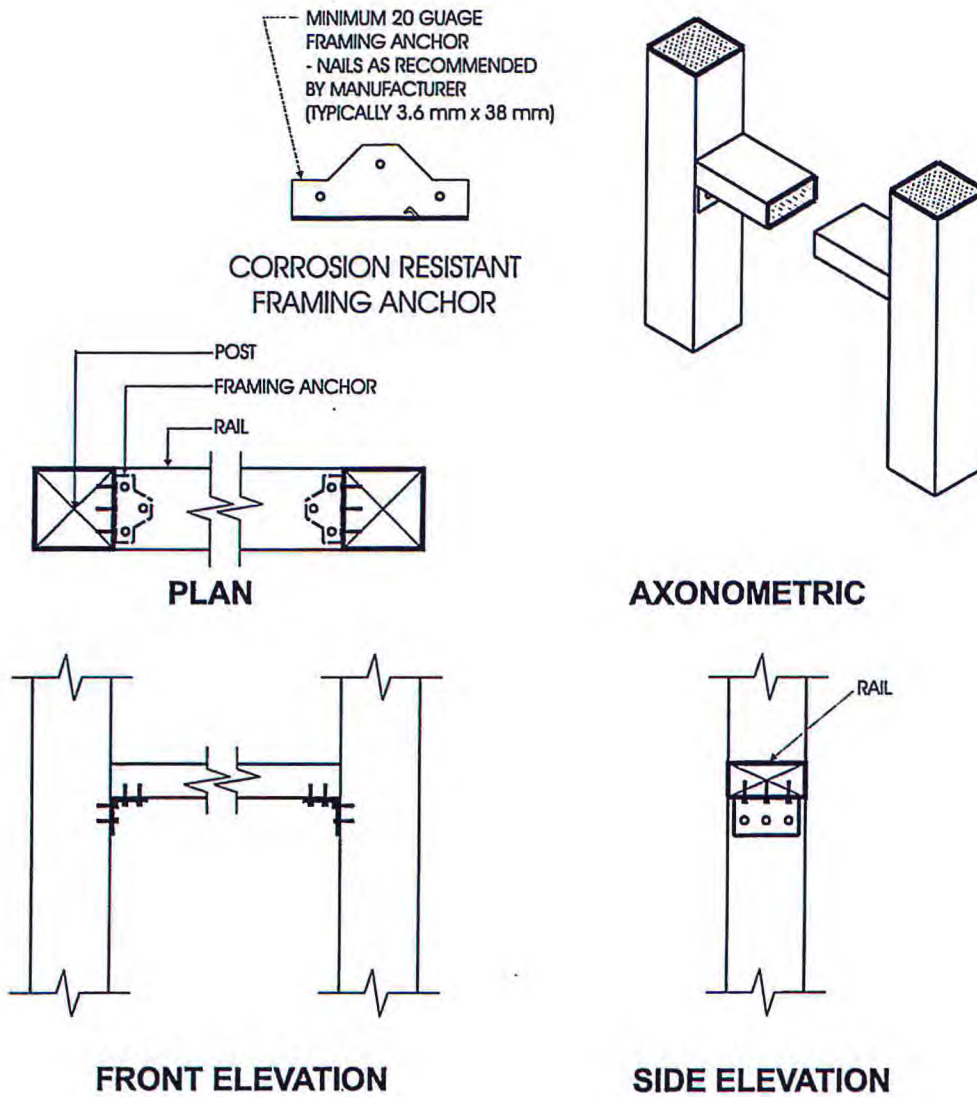

**Detail EA-5**

**Exterior Connection: Top/Bottom Rail Fastened to Post with Framing Anchors**

**Notes:**

1. Provide support to bottom rail at intervals not more than 2.0 m (6'-7").
2. The bottom rail may be bevelled as detailed in Figure 2.1.2.
3. Dimensions shown are in mm unless otherwise specified.

MAXIMUM SPAN OF RAIL BETWEEN POSTS	
Species	Maximum Span, m (ft-in)
Douglas Fir-Larch, Hem-Fir, Spruce-Pine-Fir	2.72 (8'-11")
Northern Species	2.18 (7'-2")
Column 1	2

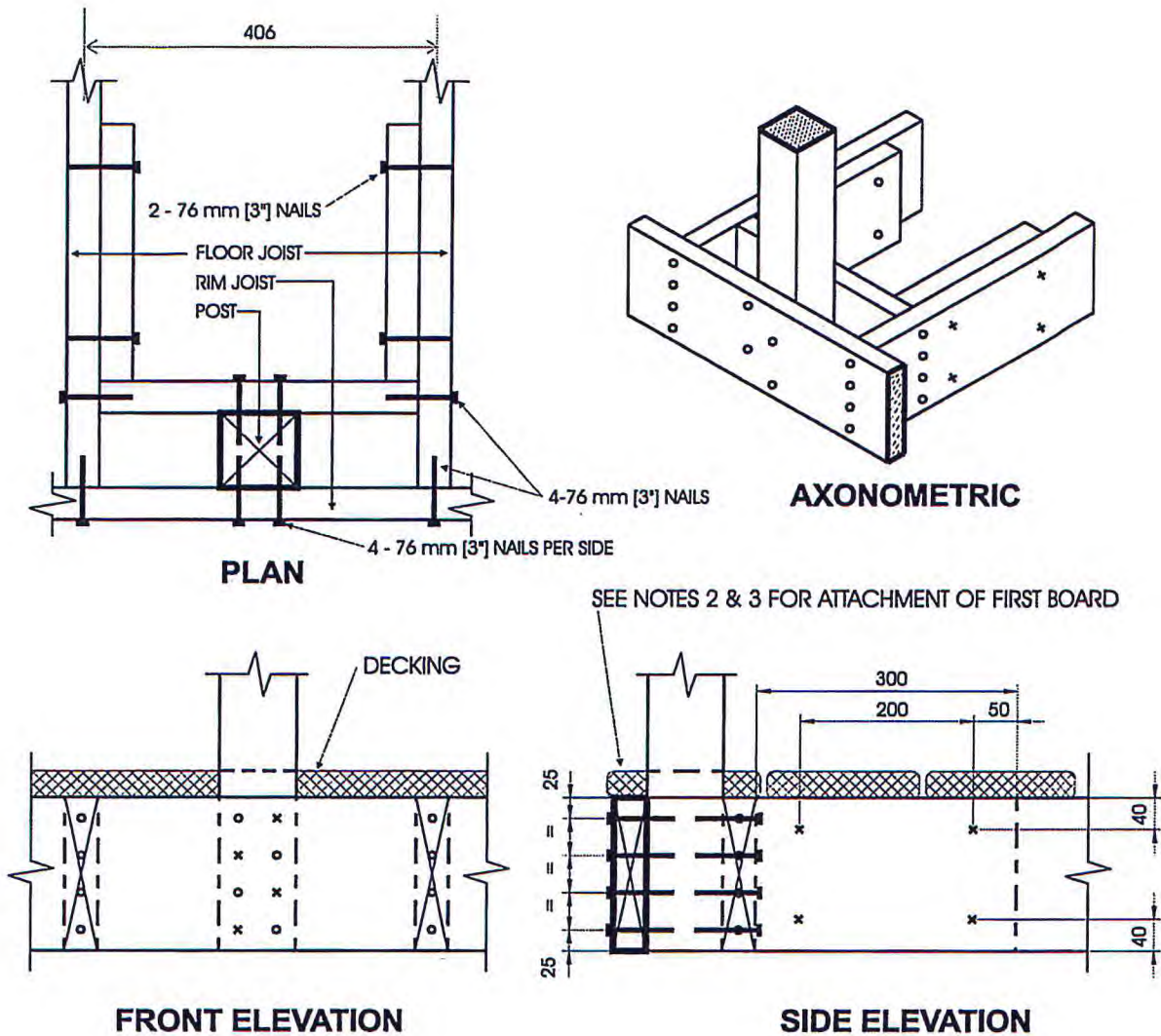

**Detail EB-1**  
**Exterior Connection: Post Nailed to Rim Joist**

**Notes:**

1. Decking is omitted from the plan view and the axonometric view for clarity.
2. Fasten 25 mm x 140 mm (5/4" x 6" nominal) outer deck board to rim joist with 63 mm (2 1/2") nails at 300 mm (12").
3. Fasten 25 mm x 140 mm (5/4" x 6" nominal) outer deck board to floor joist with 1 - 63 mm (2 1/2") nail at each joist.
4. The post may be positioned anywhere between the joists.
5. Dimensions shown are in mm unless otherwise specified.

MAXIMUM SPAN OF RAIL BETWEEN POSTS	
Species	Maximum Span, m (ft-in)
Douglas Fir-Larch, Hem-Fir, Spruce-Pine-Fir	1.22 (4'-0")
Northern Species	1.20 (3'-11")
Column 1	2

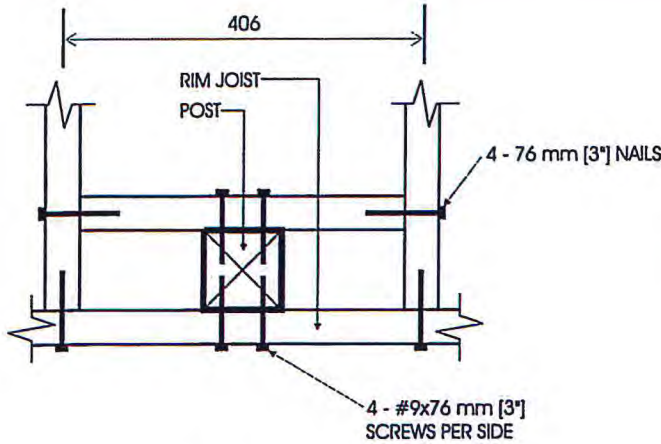

PLAN

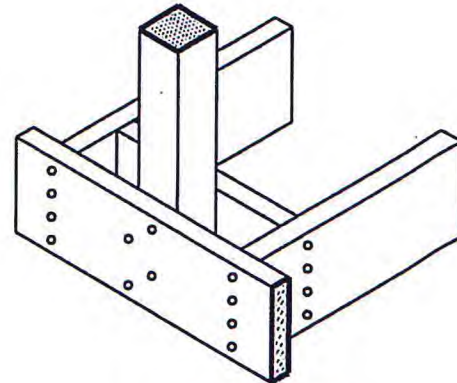

AXONOMETRIC

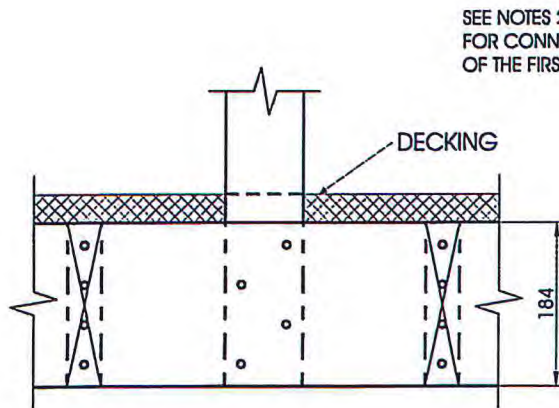

FRONT ELEVATION

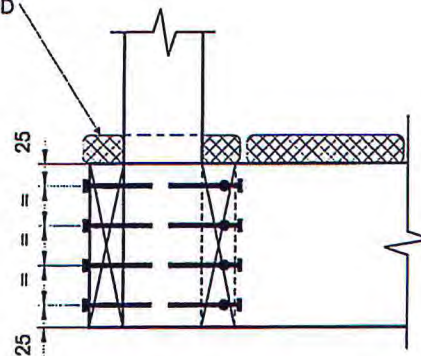

SIDE ELEVATION

**Detail EB-2**

**Exterior Connection: Post Screwed to Rim Joist**

**Notes:**

1. Decking is omitted from the plan view and the axonometric view for clarity.
2. Fasten 25 mm x 140 mm (5/4" x 6" nominal) outer deck board to rim joist with 63 mm (2 1/2") nails at 300 mm (12").
3. Fasten 25 mm x 140 mm (5/4" x 6" nominal) outer deck board to floor joist with 1 - 63 mm (2 1/2") nail at each joist.
4. The post may be positioned anywhere between the joists.
5. #9 screws may be replaced by #8 screws if the maximum spacing between posts is not more than 1.20 m (3'-11").
6. Dimensions shown are in mm unless otherwise specified.

MAXIMUM SPAN OF RAIL BETWEEN POSTS	
Species	Maximum Span, m (ft-in)
Douglas Fir-Larch, Hem-Fir, Spruce-Pine-Fir	1.56 (5'-1")
Northern Species	1.20 (3'-11")
Column 1	2

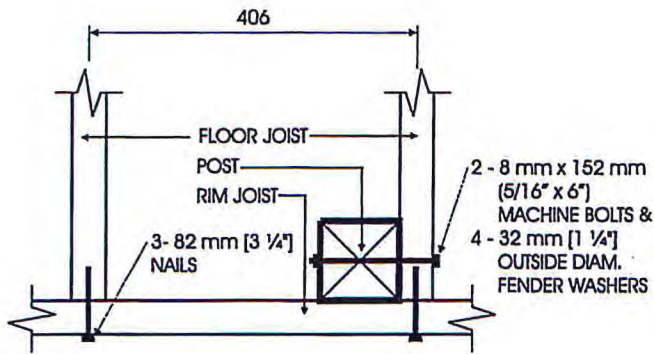

PLAN

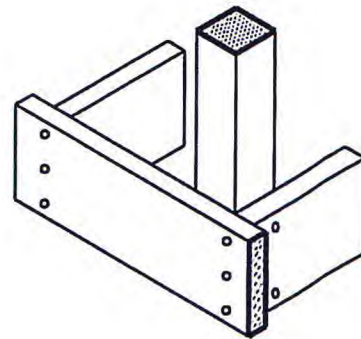

AXONOMETRIC

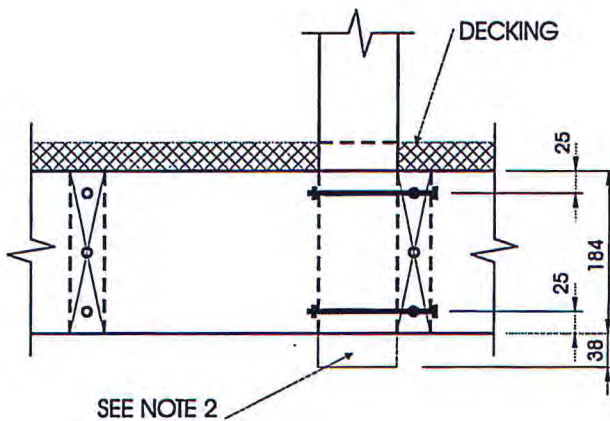

FRONT ELEVATION

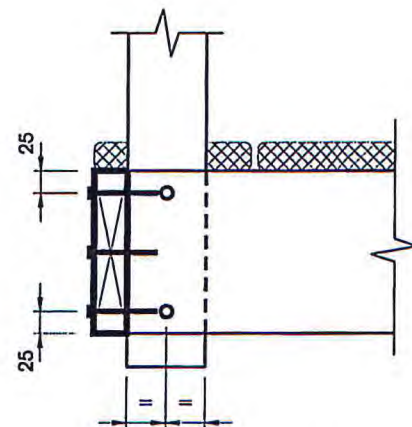

SIDE ELEVATION

**Detail EB-3**

**Exterior Connection: Post Bolted to Floor Joist - 8 mm (5/16") Bolts**

**Notes:**

1. Decking is omitted from the plan view and the axonometric view for clarity.
2. 38 mm (1 1/2") post projection is not required where the maximum spacing between posts does not exceed 1.20 m (3'-11").
3. Joists may be spaced at 610 mm (24") o.c. or 406 mm (16") o.c.
4. Where floor joists are spaced at 610 mm (24") o.c., decking shall have a minimum thickness of 38 mm (1 1/2") and shall be fastened to the floor with 2 - 76 mm (3") nails.
5. Dimensions shown are in mm unless otherwise specified.

MAXIMUM SPACING BETWEEN POSTS	
Species	Maximum Span, m (ft-in)
Douglas Fir-Larch, Hem-Fir, Spruce-Pine-Fir	1.29 (4'-3")
Northern Species	1.20 (3'-11")
Column 1	2

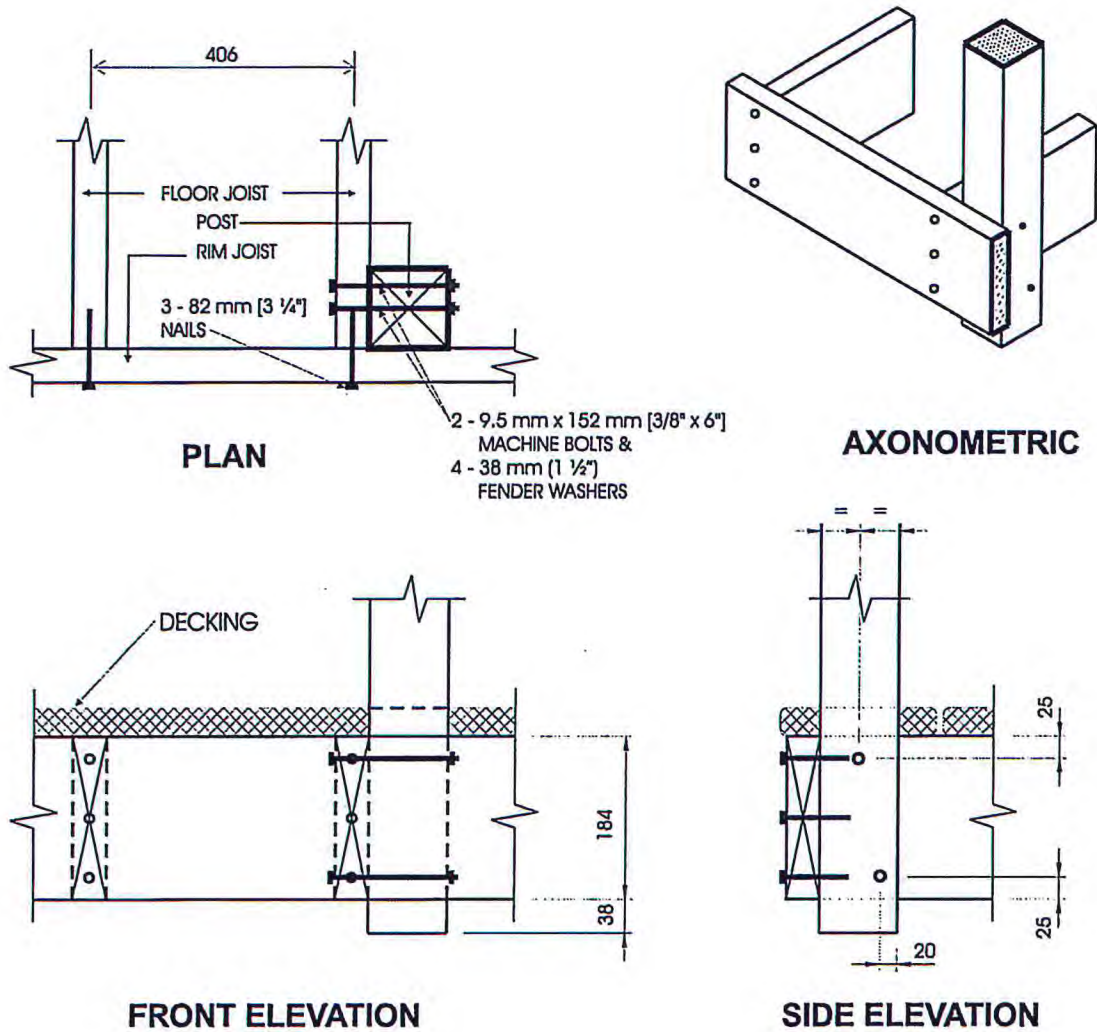

**Detail EB-4**

**Exterior Connection: Post Bolted to Floor Joist - 9.5 mm (3/8") Bolts**

**Notes:**

1. Decking is omitted from the plan view and the axonometric view for clarity.
2. 38 mm (1 1/2") post projection is not required where the maximum spacing between posts does not exceed 1.20 m (3'-11").
3. Joists may be spaced at 610 mm (24") o.c. or 406 mm (16") o.c.
4. Where floor joists are spaced at 610 mm (24") o.c., decking shall have a minimum thickness of 38 mm (1 1/2") and shall be fastened to the floor with 2 - 76 mm (3") nails.
5. Dimensions shown are in mm unless otherwise specified.

MAXIMUM SPACING BETWEEN POSTS	
Species	Maximum Span, m (ft-in)
Douglas Fir-Larch, Hem-Fir, Spruce-Pine-Fir	1.49 (4'-11")
Northern Species	1.20 (3'-11")
Column 1	2

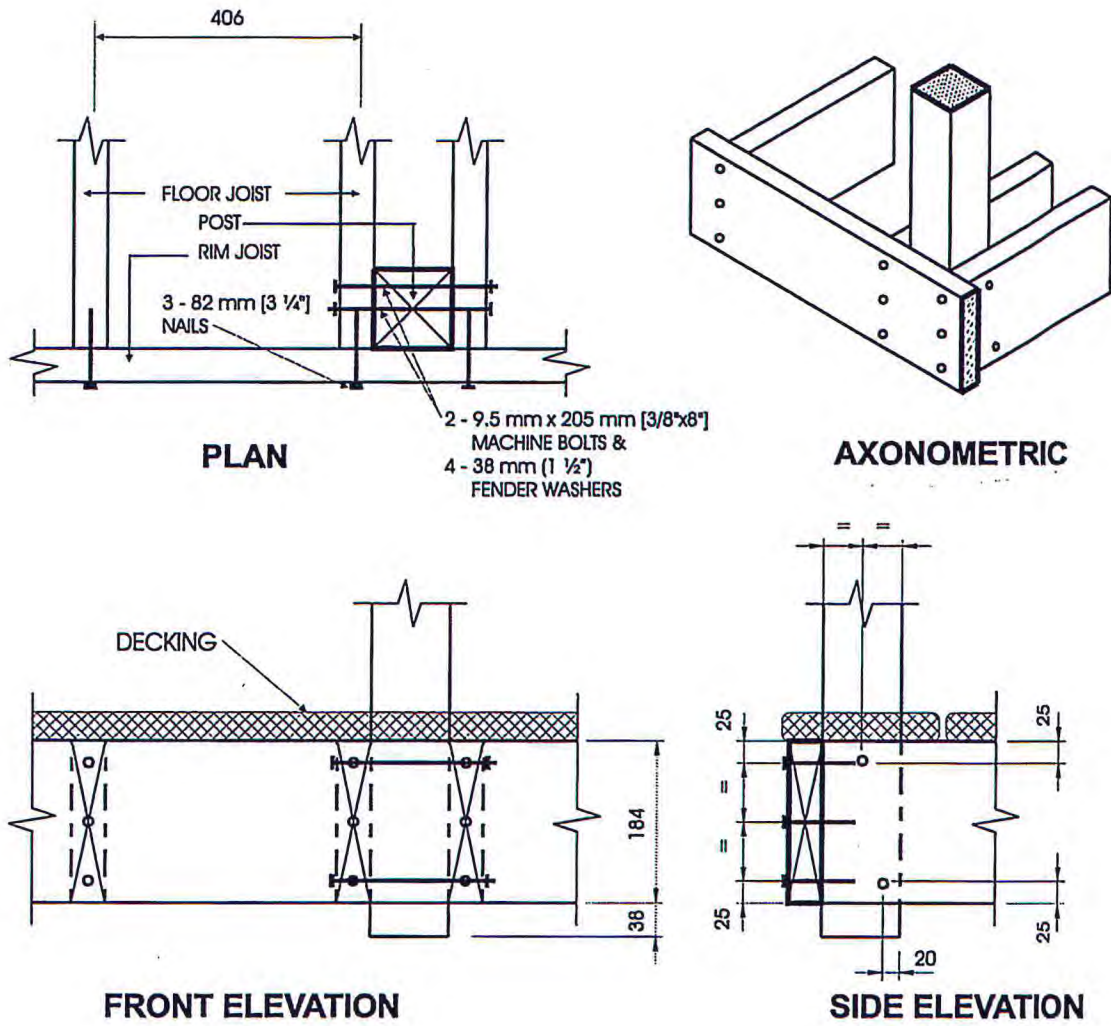

**Detail EB-5**  
**Exterior Connection: Post Bolted to 2 Floor Joists**

**Notes:**

1. Decking is omitted from the plan view and the axonometric view for clarity.
2. 38 mm (1 1/2") post projection is not required where the maximum spacing between posts does not exceed 1.20 m (3'-11").
3. Joists may be spaced at 610 mm (24") o.c. or 406 mm (16") o.c..
4. Where floor joists are spaced at 610 mm (24") o.c. decking shall have a minimum thickness of 38 mm (1 1/2") and shall be fastened to the floor with 2 - 76 mm (3") nails.
5. Dimensions shown are in mm unless otherwise specified.

MAXIMUM SPACING BETWEEN POSTS	
Species	Maximum Span, m (ft-in)
Douglas Fir-Larch, Hem-Fir, Spruce-Pine-Fir	2.14 (7'-0")
Northern Species	1.20 (3'-11")
Column 1	2

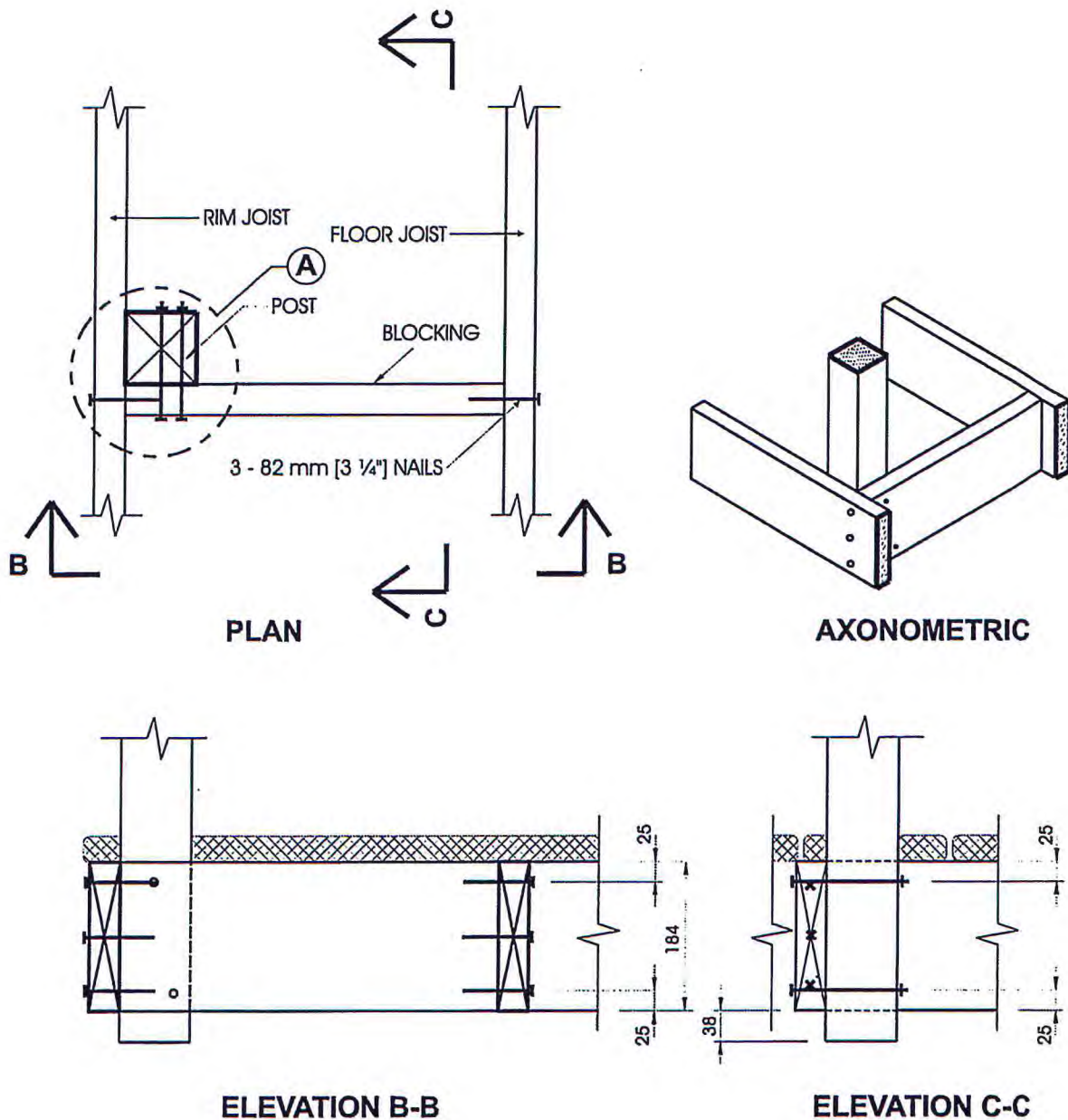

### Detail EB-6

#### Exterior Connection: Post Fastened to Floor, Guard Parallel to Floor Joists

##### Notes:

1. Use any of the connection details shown on Details EB-1 to EB-5 at location "A". Connection Detail EB-4 is shown in this detail, as an example.
2. Maximum spacing between posts is determined from connection detail used at location "A".
3. Decking is omitted from the plan view and the axonometric view for clarity.
4. Blocking shall be not less than 38 mm x 184 mm (2" x 8" nominal).
5. Dimensions shown are in mm unless otherwise specified.



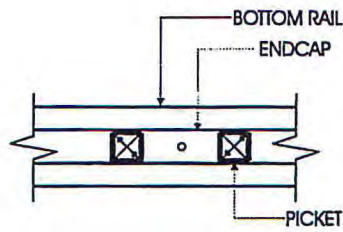

**PLAN  
BOTTOM RAIL**

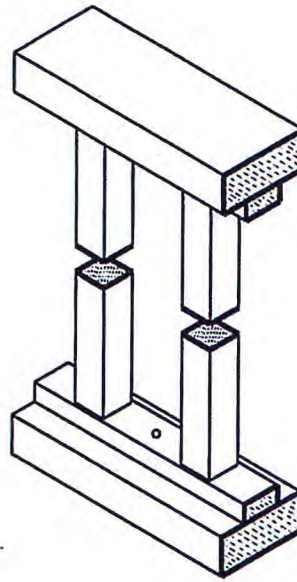

**AXONOMETRIC**

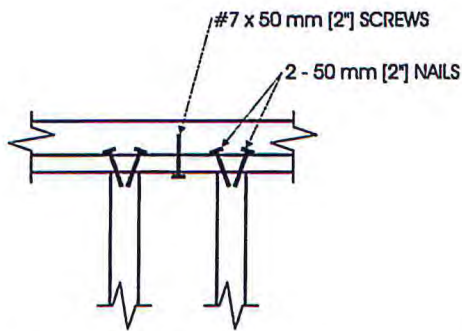

**FRONT ELEVATION**

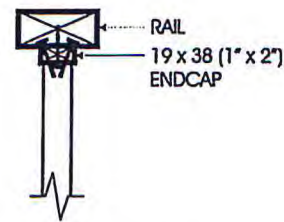

**SIDE ELEVATION**

**Detail EC-1**

**Exterior Connection: Infill Picket Nailed to Endcap - Endcap Screwed to Rail**

**Notes:**

1. Fasten each end of each picket to endcaps with 2 - 50 mm (2") nails.
2. Fasten endcaps to rails with #7 x 50 mm (2") screws at 300 mm (12") o.c.
3. See Table 2.1.2. for minimum sizes of pickets.

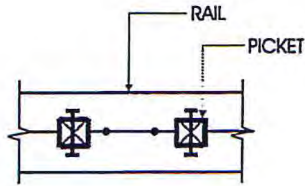

**PLAN  
BOTTOM RAIL**

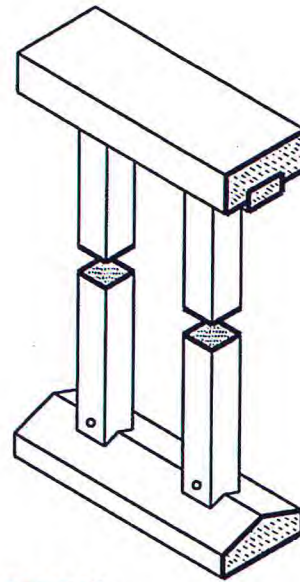

**AXONOMETRIC**

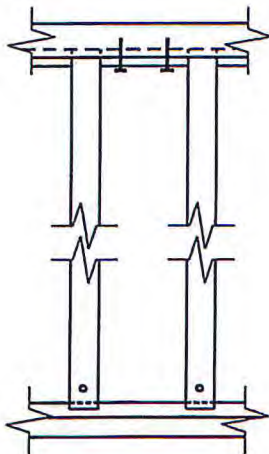

**FRONT ELEVATION**

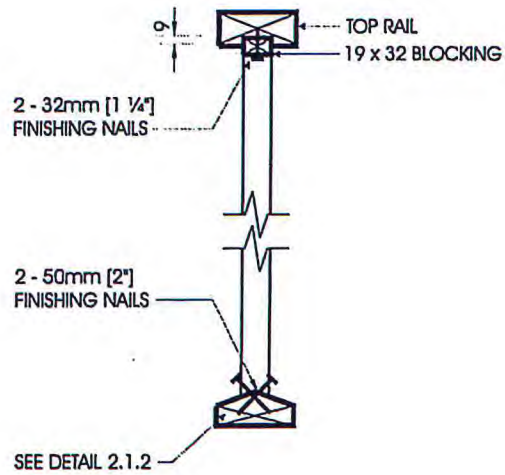

**SIDE ELEVATION**

**Detail EC-2**

**Exterior Connection: Infill Picket Nailed to Rail**

**Notes:**

1. See Table 2.1.2. for minimum sizes of pickets.
2. Dimensions shown are in mm unless otherwise specified.

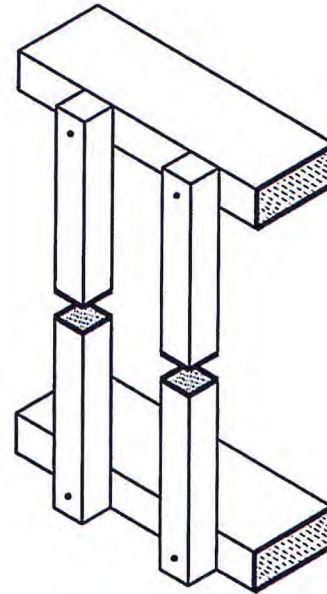
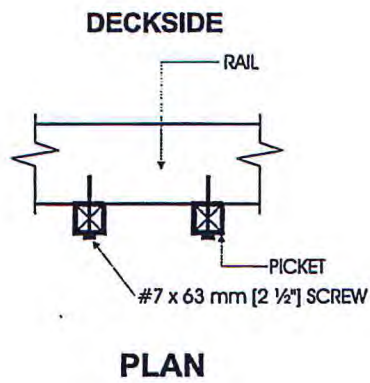

AXONOMETRIC

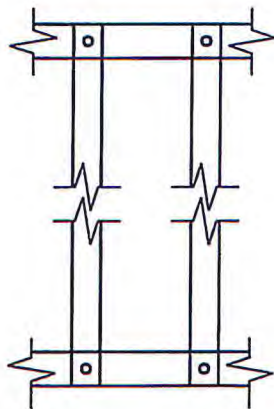

FRONT ELEVATION



SIDE ELEVATION

**Detail EC-3**

**Exterior Connection: Infill Picket Screwed to Rail**

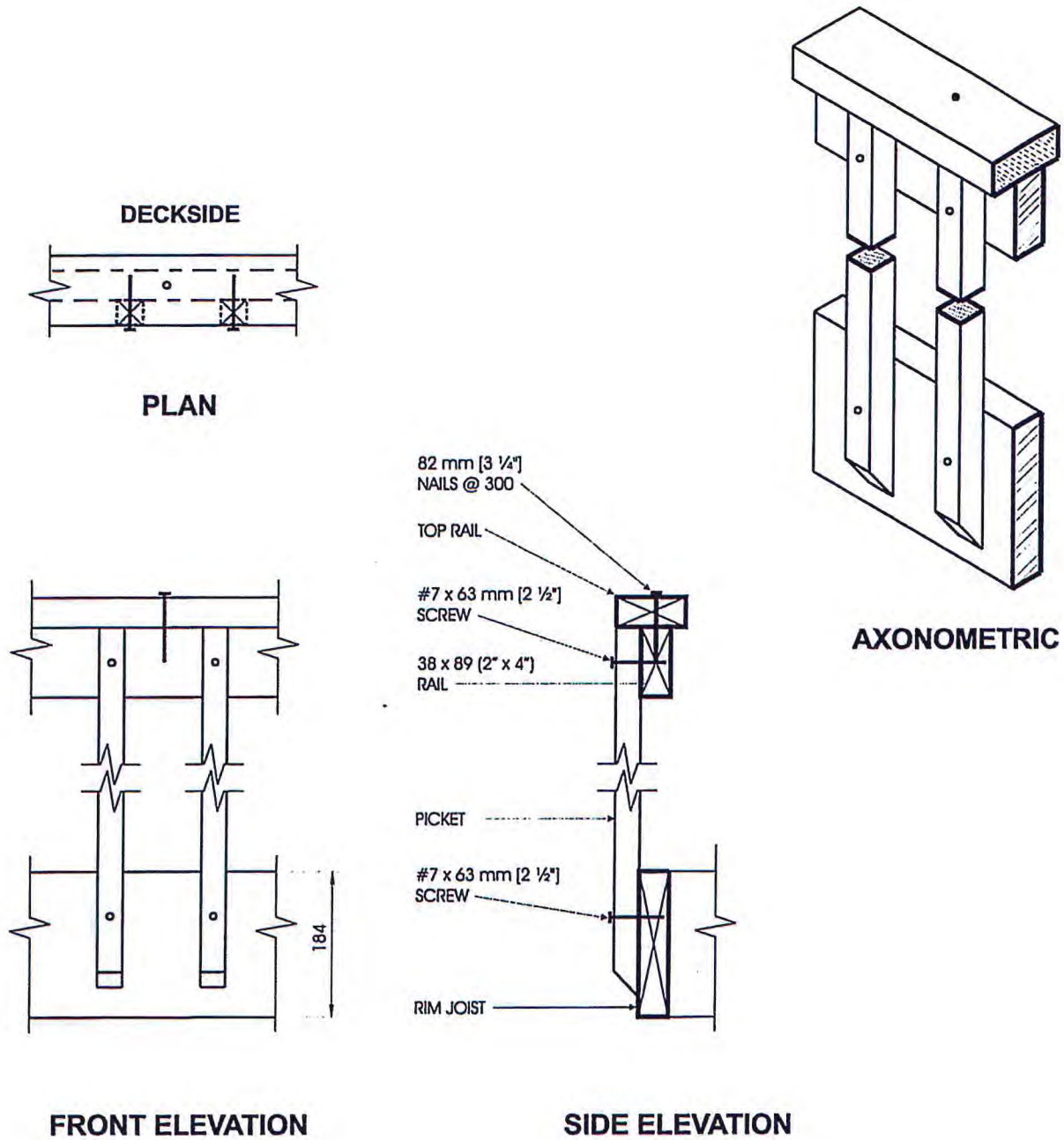

**Detail EC-4**

**Exterior Connection: Infill Picket Screwed to Top Rail and Rim Joist**

**Note:**

1. Dimensions shown are in mm unless otherwise specified.

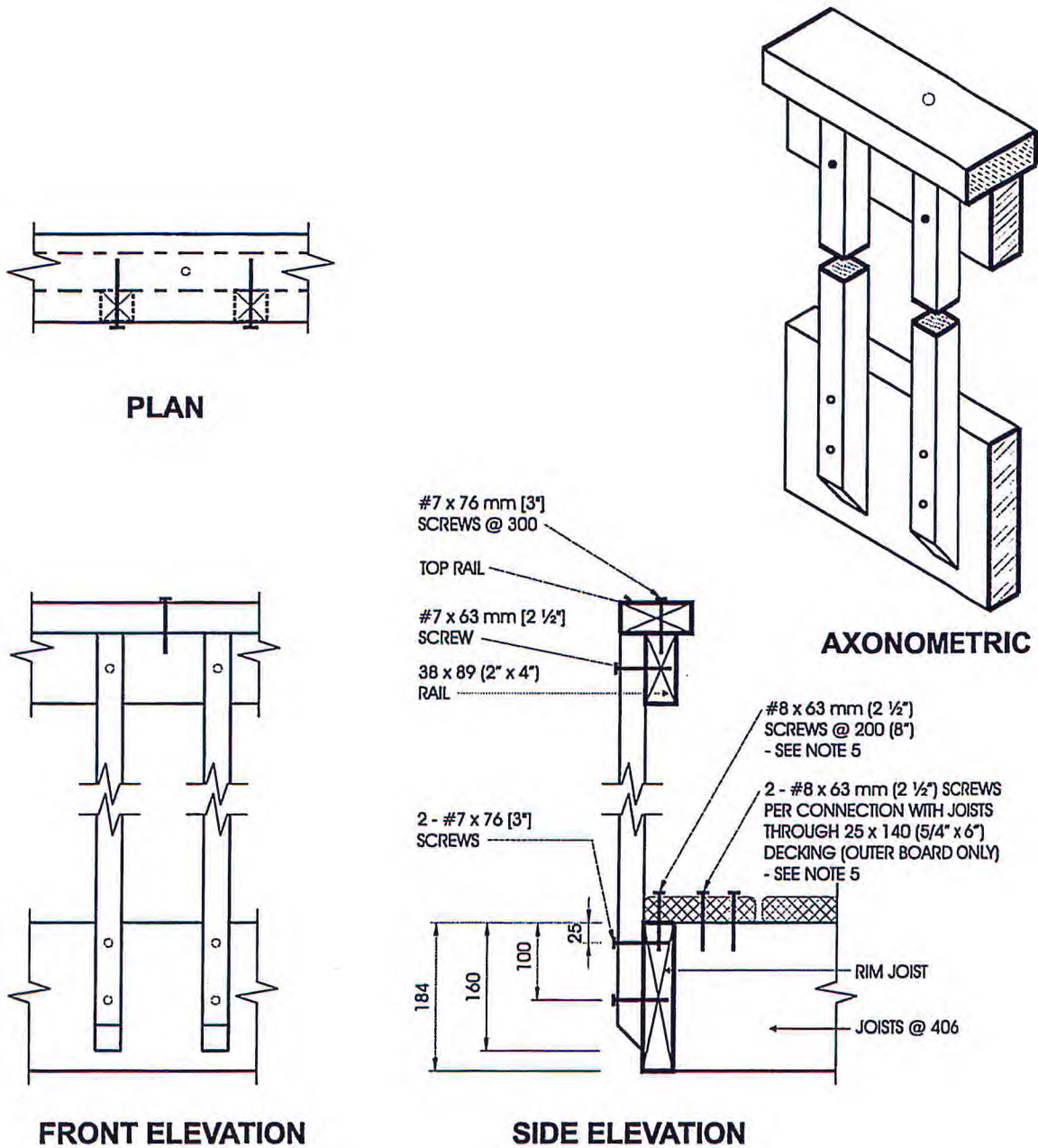

**Detail ED-1**

**Exterior Connection: Cantilevered Picket Screwed to Rim Joist**

**Notes:**

1. Provide a suitable post, return, or solid support at each end of the guard.
2. Wood for cantilevered pickets shall be Douglas Fir-Larch, Spruce-Pine-Fir, or Hem-Fir Species.
3. Fasten rim joist to each floor joist with 3 - 82 mm (3 1/4") nails.
4. Dimensions shown are in mm unless otherwise specified.
5. The outer deck board shall not be less than 140 mm (6" nominal) wide. Where 38 mm (2" nominal) thick boards are used, the length of the wood screws shall be not less than 76 mm (3").

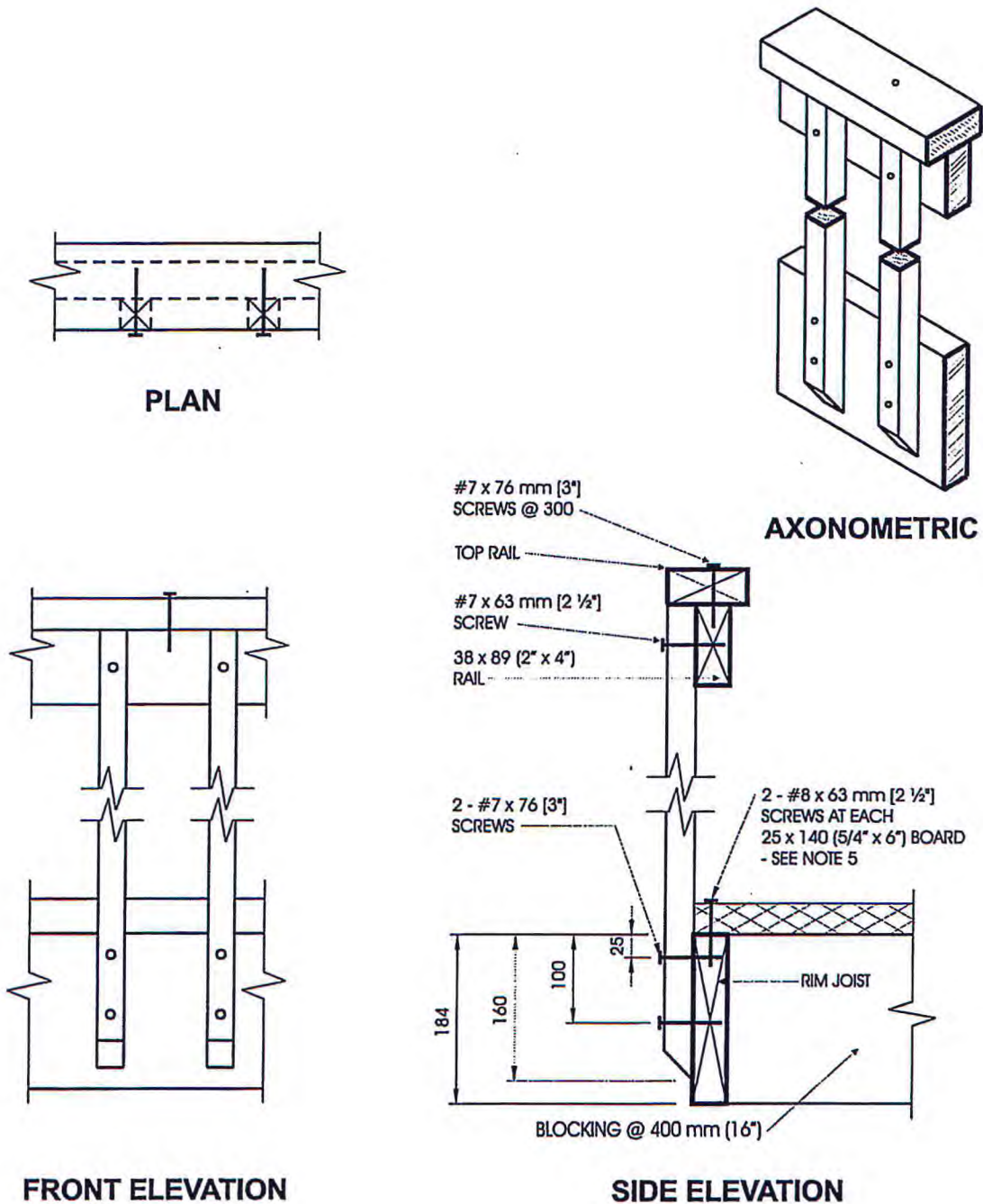

**Detail ED-2**

**Exterior Connection: Cantilevered Picket Screwed to Rim Joist,  
Guard Parallel to Floor Joists**

**Notes:**

1. Provide a suitable post, return, or solid support at each end of the guard.
2. Wood for cantilevered pickets shall be Douglas Fir-Larch, Spruce-Pine-Fir, or Hem-Fir Species.
3. Fasten rim joist to blocking with 3 - 82 mm (3 1/4") nails.
4. Dimensions shown are in mm unless otherwise specified.
5. Where 38 mm (2" nominal) thick boards are used, the length of the wood screws shall be not less than 76 mm (3").

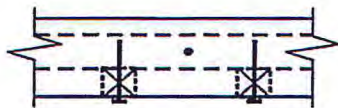

PLAN

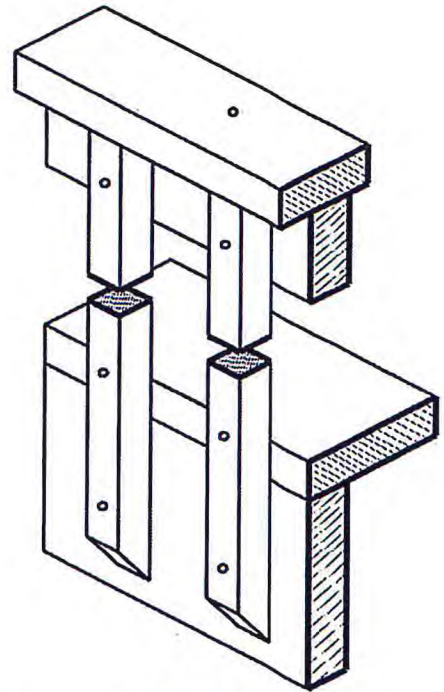

AXONOMETRIC

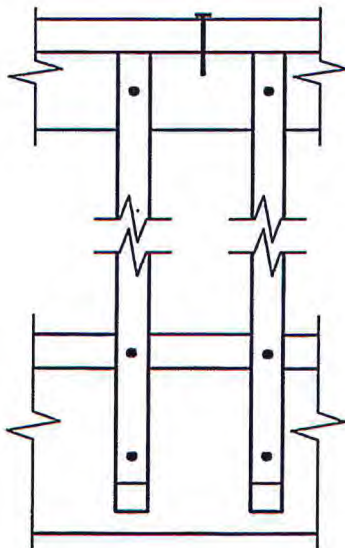

FRONT ELEVATION

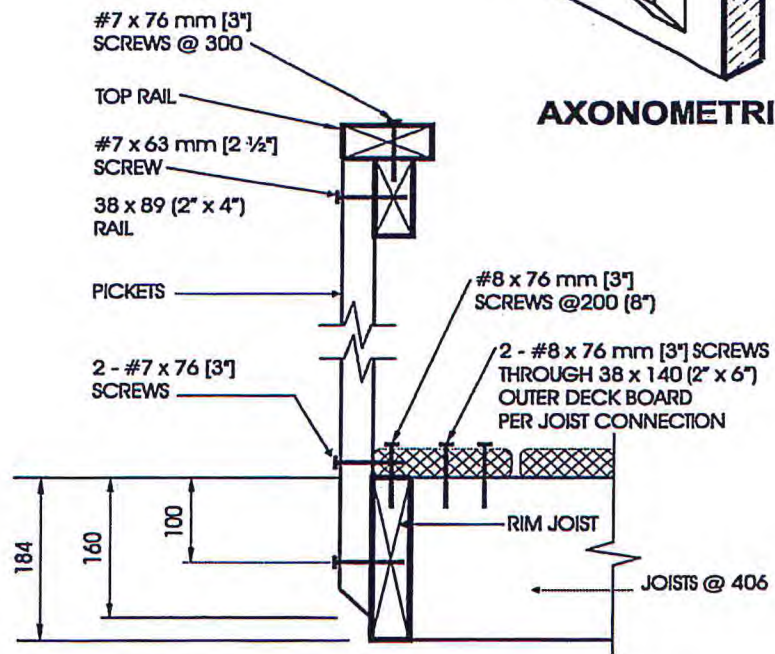

SIDE ELEVATION

**Detail ED-3**

**Exterior Connection: Cantilevered Picket Screwed to Rim Joist and Deck**

**Notes:**

1. Provide a suitable post, return, or solid support at each end of the guard.
2. Wood for cantilevered pickets shall be Northern Species.
3. Fasten rim joist to each floor joist with 3- 82 mm (3 1/4") nails.
4. Dimensions shown are in mm unless otherwise specified.

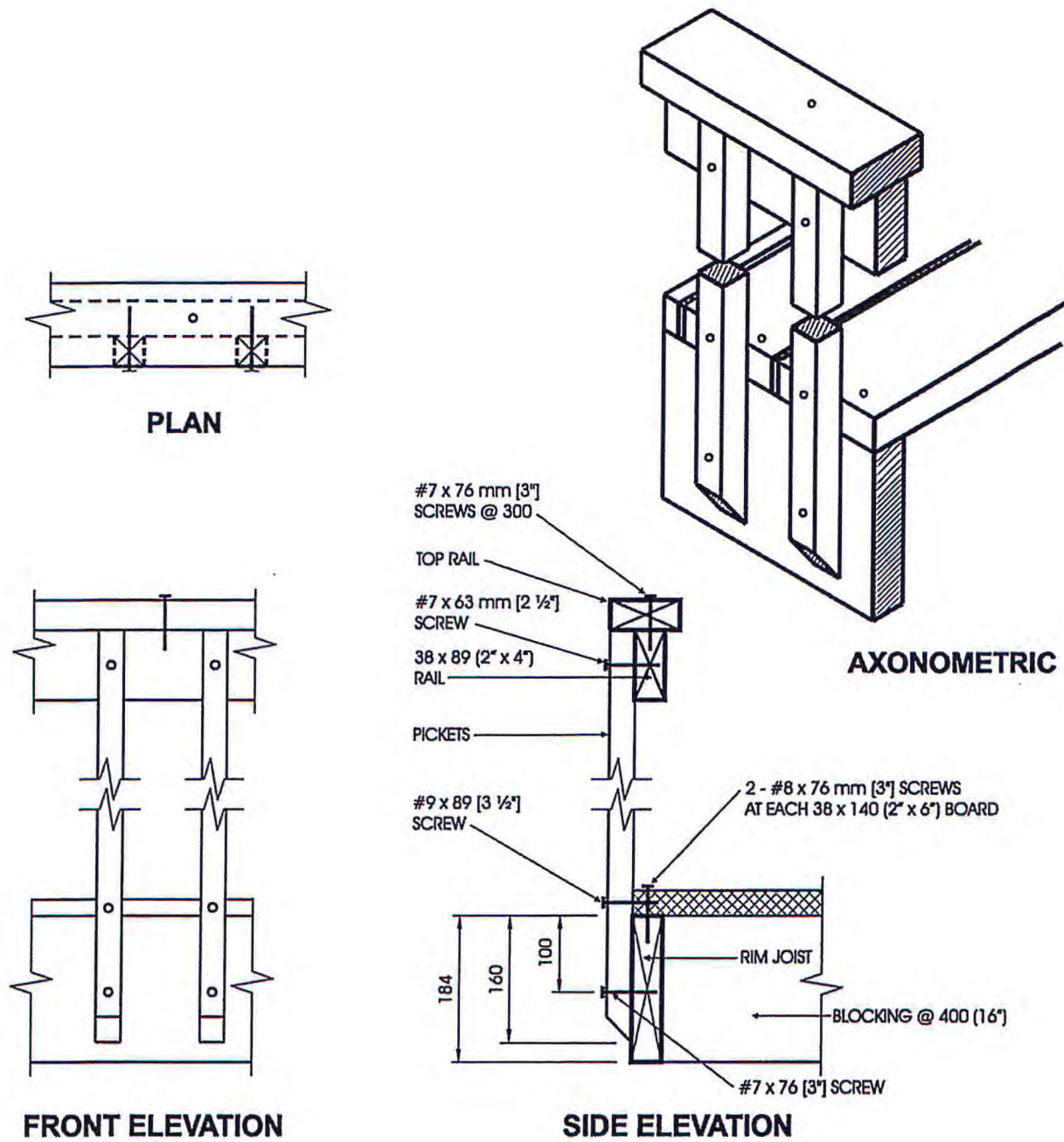

**Detail ED-4**

**Exterior Connection: Cantilevered Picket Screwed to Rim Joist and Deck, Guard Parallel to Floor Joists**

**Notes:**

1. Provide a suitable post, return, or solid support at each end of the guard.
2. Wood for cantilevered pickets shall be Northern Species.
3. Fasten rim joist to blocking with 3 - 82 mm (3 1/4") nails.
4. Dimensions shown are in mm unless otherwise specified.



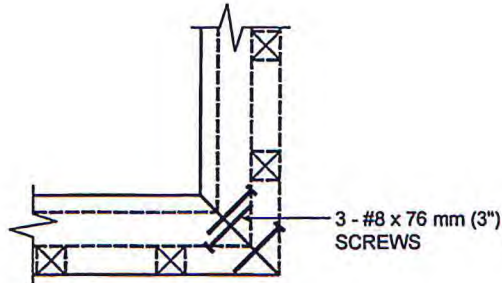

PLAN TOP RAIL

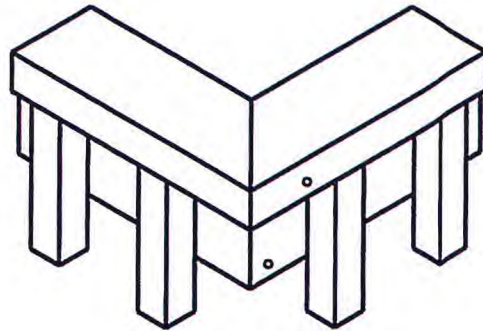

AXONOMETRIC

ONE FASTENER IN HORIZONTALLY ORIENTATED PORTION OF TOP RAIL  
AND TWO IN VERTICALLY ORIENTATED PORTION.

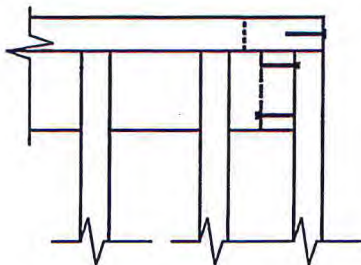

FRONT TOP RAIL

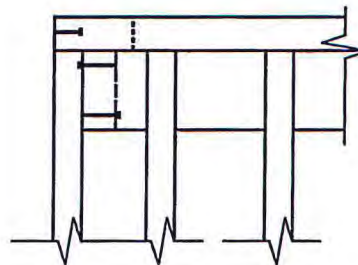

SIDE TOP RAIL

**Detail ED-5**

**Exterior Connection: Corner Joint**

**Notes:**

1. Screws fastening pickets are omitted for clarity.
2. Provide a minimum of 10 pickets beyond the return if end restraint of the guard is provided by this return detail only.

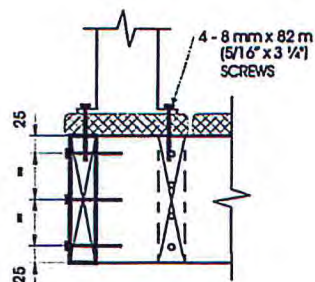
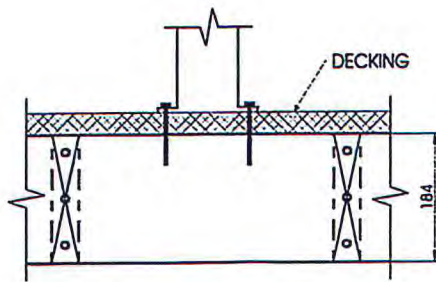
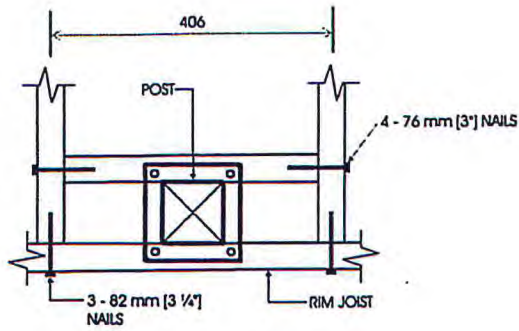
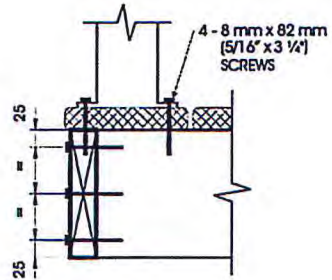
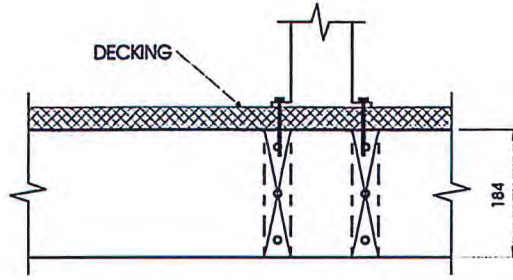
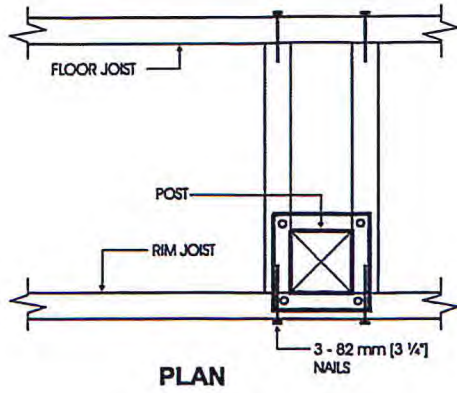

**TACBOC**  
STANDARD DETAIL

TITLE  
WOOD DECK  
CONSTRUCTION DETAILS,  
PLAN & SECTION

DWG. NO.

DOLF

03-2012

## THE APPROVAL PROCESS

Depending on the complexity of your project, your application may be reviewed in three stages:

- 1) Planning Department staff will check for compliance with the regulations and provisions of the zoning by-law such as proposed use, minimum setback requirements, lot coverage and building height, etc.
- 2) Building Department staff will review the proposed construction to ensure compliance with the Ontario Building Code.
- 3) Engineering Department staff will review the project for compliance with lot grading and servicing requirements.

If during the review an examiner identifies deficiencies on the drawings or requires additional information, the designer and/or applicant will be notified.

Please ensure that the necessary information is submitted promptly, as subject to the type of deficiency no further processing may occur until the information is received.

When the review of your application is completed and all requirements have been met, your building permit will be available. Applicant will be notified.

**\* *It is unlawful to start construction without the necessary permits. If you start construction without the necessary permits, you may be ordered to stop work, ordered to remove work already done, or prosecuted. THE PERMIT FEE WILL BE DOUBLED.***

**\*\* *Once you receive your permit, ensure that the permit and approved drawings are available on the construction site.***

### **Inspections**

Construction may commence upon issuance of the Building Permit. Several inspections are required to ensure that all work is done according to the approved plans including changes noted by the plans examiner. You will be issued a list of the required inspections for your specific project.

Examples of construction stages when inspections are required are on the attached copy of an 'Order Not to Cover'.

Inspections do not happen automatically. It is **your responsibility** to ensure that either you or your contractor contacts the Town to request an inspection at least 24

hours before work proceeds from one inspection stage to the next. This will ensure that your project proceeds as approved.

Failure to have inspections performed may result in having to **uncover and expose work** for inspections. For inspections call 905-372-1005.

### Other Inspections

- Electrical
- Plumbing
- Gas

***\* Remember to call for the location of utilities before you dig***

<b>CONTACTS</b>	
<b>Building &amp; Planning Department</b> 55 King Street West Victoria Hall Cobourg ON K9A 2M2 905-372-1005	<b>Engineering Department</b> 55 King Street West Victoria Hall Cobourg ON K9A 2M2 905-372-4555
<b>Lakefront Utilities (LUSI/LUI)</b> 207 Division Street P.O. Box 577 Cobourg ON K9A 4L3 905-372-2193	<b>Ganaraska Region Conservation Authority (GRCA)</b> P.O. Box 328 Port Hope, ON L1A 3W4 905-885-8173
<b>District Health Unit</b> 200 Rose Glenn Road P.O. Box 90 Port Hope ON L1A 3V6 905-885-9100	<b>Plumbing Inspection</b> Northumberland County 555 Courthouse Road Cobourg ON K9A 5J6 905-372-1929
<b>Electrical Safety Authority</b> Electrical Inspection Peterborough ON 1-877-372-7233	<b>Fire Department</b> 111 Elgin Street East Cobourg ON K9A 1A1 905-372-9789
<b>Ontario One Call (Underground Locates)</b> 1-800-400-2255	<b>Union Gas</b> 1-888-774-3111

**The Building Code Act and the Ontario Building Code can be found online at:**

**[www.e-laws.gov.on.ca](http://www.e-laws.gov.on.ca)**

**Search for "Building Code"**